



## INTRODUCTION

The goal of the ESF is to ensure that vehicles are as safe as possible, and that they comply with the Formula-Hybrid completion rules. The ESF is divided seven main sections:

1. Overview
2. Cables, Fusing & Grounding
3. Isolation & Insulation
4. Electric Tractive System
5. Accumulator System
6. Safety Controls and Indicators
7. GLV System

The Cables and Fusing, and Insulation and Isolation sections are at the beginning of the ESF as these are the areas where teams most often have trouble in complying with FH rules.

A clear, concise ESF will help you to build a better car. It will also help you to pass tech testing as most common tech problems can be addressed before the car reaches the track.

### **IMPORTANT INSTRUCTIONS AND REQUIREMENTS**

1. Every part of this ESF must be filled with content. If a section is not relevant to your vehicle, mark it as “N/A” and describe briefly why not.
2. Leave the written instructions in place and add your responses below them.
3. All figures and tables must be included. An ESF with incomplete tables or figures will be rejected.
4. The maximum length of a complete ESF is 100 pages.
5. Note that many fields ask for information that was submitted in your ESF-1. This information must be reentered – in some cases will be different than what was entered in ESF-1, which is OK.
6. When completed, this document must be converted to a pdf and submitted to: <http://formula-hybrid.com/uploads/>

Please submit any questions, corrections and suggestions for improvement to: <http://www.formula-hybrid.org/level2/support>

## REVIEW PROCESS

Once submitted, your ESF will be reviewed by at least two FH reviewers. One will be the designated primary reviewer for your team.

Feedback on your ESF occurs through the Formula Hybrid upload system. You will receive emails via this system from your reviewers offering guidance and feedback. You will also submit revised versions of your ESF in this system. When you submit a revised ESF, please indicate the REVISION DATE AND LETTER (starting with Letter A) and which sections have been updated in the following table:

REVISION DATE	May 1, 2014
REVISION (A, B, C, etc...)	B
Section	Revised (Yes/No)
1- Overview	No
2- Cables and Fusing	Yes
3- Insulation and Isolation	No
4- Electric Tractive System	No
5- Accumulator System	Yes
6- GLV System	No
7- Safety Controls and Indicators	No
8- Appendices/Datasheets	No



## ESF Part 2

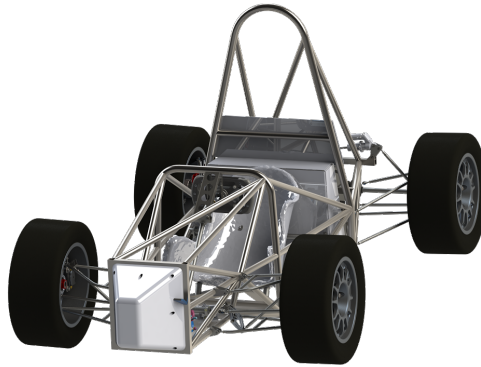

---

University Name: Olin College of Engineering  
Team Name: REVO Electric Racing  
Car Number: E212

---

### Main Team Contact for ESF related questions:

---

Name: Lisa J. Hachmann  
email: [lisa.hachmann@students.olin.edu](mailto:lisa.hachmann@students.olin.edu)

---

# Contents

<b>List of Tables</b>	<b>5</b>
<b>List of Abbreviations</b>	<b>6</b>
<b>1 Vehicle Overview</b>	<b>7</b>
<b>2 Cables, Fusing &amp; Grounding</b>	<b>13</b>
2.1 Fusing and Overcurrent Protection . . . . .	13
2.2 Component Fusing . . . . .	13
2.3 System Wire Tables . . . . .	14
2.4 Grounding System . . . . .	16
2.5 Conductive Panel Grounding . . . . .	16
<b>3 Isolation and Insulation</b>	<b>16</b>
3.1 Separation of Tractive System and Grounded Low Voltage System . . . . .	16
3.2 Isolation and Insulation . . . . .	22
3.3 Conduit . . . . .	22
3.4 Shielded Dual-Insulated Cable . . . . .	23
3.5 Firewall(s) . . . . .	23
<b>4 Electric Tractive System</b>	<b>24</b>
4.1 Motor(s) . . . . .	25
4.2 Motor Controller . . . . .	25
4.3 Tractive System Measurement Points (TSMP) . . . . .	25
4.4 Pre-Charge System . . . . .	28
4.5 Discharge System . . . . .	30
4.6 High Voltage Disconnect (HVD) . . . . .	32
4.7 Accelerator Actuator / Throttle Position Sensor . . . . .	33
4.8 Accelerator / Throttle Position Encoder Error Check . . . . .	34
<b>5 Accumulator System</b>	<b>35</b>
5.1 Accumulator Pack . . . . .	35
5.2 Cell Description . . . . .	36
5.3 Cell Configuration . . . . .	37
5.4 Segment Maintenance Disconnect . . . . .	37
5.5 Lithium Ion Pouch Cells . . . . .	38
5.6 Cell Temperature Monitoring . . . . .	38
5.7 Accumulator Isolation Relays . . . . .	40
5.8 Accumulator Management System . . . . .	41
5.9 Accumulator Wiring, Cables, Current Calculations . . . . .	49
5.10 Accumulator Indicator . . . . .	51
5.11 Charging . . . . .	52
5.12 Accumulator Container/Housing . . . . .	55
<b>6 Safety Controls and Indicators</b>	<b>58</b>
6.1 Shutdown circuit . . . . .	58
6.2 IMD . . . . .	63
6.3 Reset / Latching for IMD and AMS . . . . .	64
6.4 Shutdown System Interlocks . . . . .	64
6.5 Tractive System Energized Light (TSEL) . . . . .	65
6.6 Tractive System Voltage Present light (TSVP) . . . . .	65
6.7 Ready-To-Drive-Sound (RTDS) . . . . .	66

<b>7</b>	<b>GLV system</b>	<b>67</b>
7.1	GLV System Data	67
<b>8</b>	<b>Appendices</b>	<b>67</b>

## List of Figures

1	Tractive System Block Diagram	9
2	Full Vehicle, Top View	10
3	Full Vehicle, Side View	10
4	Full Vehicle, Front View	11
5	Tractive system schematic. For wiring of the AMS, please see figure 43. Please note that the precharge has additional circuitry (for feedback timing), which is clarified in figure 19 for simplicity	12
6	Capture of the separation on each AMS board between TS and GLV power on the top copper (262 mil)	17
7	Capture of the separation on each AMS board between TS and GLV power on the top copper (264 mil)	17
8	Capture of the separation on each AMS board between TS and GLV power on the top copper (300 mil)	18
9	Capture of the separation on each AMS board between TS and GLV power on the bottom copper(291 mil)	18
10	Capture of the separation on each AMS board between TS and GLV power on the bottom copper (349 mil)	18
11	Capture of the separation on each AMS board between TS and GLV power on the bottom copper (253 mil)	19
12	AIR control board, with the bright blue line denoting the separation between the TS and GLV voltage. The smallest separation is 8.5 mm (over surface)	19
13	Side Panel board, with the bright blue line denoting the separation between the TS and GLV voltage. The smallest separation is 1/4 in (over surface)	20
14	Motor Controller Isolation board, which has a bright blue line denoting the separation between the TS and GLV voltage. The spacing is 6.731 mm. consistently (over surface)	21
15	Exploded view of the firewall	24
16	Photograph of the installed firewall's position in the car	24
17	TSMP Schematic, with and without multimeter probes.	26
18	Close up of TSMP pcb footprints (highlighted in green) on the side panel PCB. Note the bright cyan line of isolation between the GLV and TS.	28
19	Precharge System Schematic	29
20	Measured Precharge voltage for both the motor and the keyswitch activation	29
21	Schematic of the discharge system	30
22	Calculated discharge voltage vs. time	31
23	Calculated discharge current vs. time	31
24	Calculated discharge power vs. time	32
25	Electrical connections of the HVD	33
26	Anderson Power Products SB Smart VEH-G12 HVD	33
27	Schematic of the bulkhead, which has potentiometer inputs for throttle	34
28	Motor controller controller schematic	34
29	Schematic of one module, which includes 4 cells in a 2s-2p configuration, with shutdown separators in each cell	37
30	Inside view of a module	38
31	Schematic of the temperature monitoring in one segment (3 modules)	39
32	The location of the busbars, as seen on 2/4 segments.	39

33	Side view of the busbar-thermistor stackup, with aluminum nuts between the thermistors (the ring terminals shown) and the copper busbars. . . . .	40
34	Switching specification for the AIR relay datasheet . . . . .	41
35	PCB CAD of the AIR control board. The cyan line dictates the separation between GLV and TS voltages. . . . .	41
36	AIR control board schematic, not including the economizers . . . . .	42
37	Accumulator, Front View . . . . .	43
38	Voltage measured at BMS vs. temperature the cell is at. . . . .	44
39	Voltage measured at BMS vs. temperature the cell is at. This just shows the voltage difference at different temperatures around 60 °C . . . . .	45
40	Schematic of the cell-top board . . . . .	46
41	The left-side version of the cell top board that connects battery information to the AMS. . . . .	46
42	The right-side version of the cell top board that connects battery information to the AMS. . . . .	47
44	Accumulator Management System PCB . . . . .	47
43	Accumulator Management System schematic . . . . .	48
45	Side view of accumulator wiring: All wiring passes through grommets to the top of the pack. Modules within segments are connected using copper bus bars. Cell top boards allow connection of the AMS to individual modules. . . . .	49
46	Top view of accumulator wiring: TS wiring is routed through 3 SMDs in order to segment the accumulator. The pack is fused before the Ts+ AIR then connected to the HVD. The high voltage line is split within the accumulator for the two independent motor controllers. The AMS is located in the center of the pack and monitors cell health during driving and charging. The AIR Control Board links the shutdown circuit to the AIRs and is externally connected with AMPSEAL connectors. . . . .	50
47	Schematic of the accumulator indicator . . . . .	52
48	Zoom in on the section of the PCB containing the accumulator indicator (the AIR control board) . . . . .	52
49	Visual of the charger from the Delta Q Technologies QioQ 1000 Series . . . . .	53
50	Schematic of the charging shutdown system, not including the AMS and its relays (located on the AIR control board). The connections to the Air control board are made through the 14-pin connector . . . . .	53
51	CAD of the charging shutdown PCB. All connections on the PCB will be low voltage. . . . .	54
52	Cart with a deadman's lock for carrying the accumulator . . . . .	55
53	Accumulator Frame Exploded View . . . . .	56
54	Sheet metal construction of the accumulator, isometric . . . . .	57
55	Overall view of the accumulator container, with the lid on. . . . .	57
56	Shutdown system schematic . . . . .	59
58	Side Mounted Shutdown Buttons mounted on cars: Easily visible and accessible for E-Stop rescue scenarios . . . . .	60
57	The side panel PCB contains most of the shutdown circuitry, and can be found in the motor controller housing. . . . .	61
59	Cockpit Shutdown Button: E-Stop button for driver controlled shutdown . . . . .	62
60	Brake Over-travel Switch: The BOTS is mounted to a sheet metal container which is mounted to the pedal assembly. An aluminum nut threaded over the BOTS acts as the positive stop for the pedal, transmitting the pedal load into the sheet metal rather than the switch itself. . . . .	62
61	Motor Controller Housing Outside View Diagram- this contains the side panel PCB, MCC PCB and motor controllers inside (both Tractive and GLV components). . . . .	63
62	Motor Controller Housing Inside View Diagram . . . . .	63
63	Schematic of the IMD . . . . .	64
64	Schematic of the interlocks as a part of the shutdown circuit . . . . .	65
65	Schematic of the TSEL . . . . .	65
66	Schematic of the TSVPs . . . . .	66
67	Schematic for the Ready to Drive Sound . . . . .	66
68	Schematic showing the branching, fusing and control of the GLV line . . . . .	67

69 Selection of Appendix A used to determine accumulator capacity . . . . . 83



## List of Tables

1	General Electrical System Parameters	13
2	Fuse Table	13
3	Component Fuse Ratings	14
4	System wire table	15
5	PCB Spacings	17
6	Purchased Components - Isolation Data	22
7	List of Containers with TS and GLV wiring	22
8	Insulating Materials	22
9	Conduit Data	23
10	Shielded Dual Insulated Cable Data	23
11	Motor Data	25
12	Motor Controller Data	26
13	TSMP Resistor Data	27
14	Data for the pre-charge resistor	30
15	Data of the pre-charge relay	30
16	Data of the discharge circuit	32
17	Throttle Position Encoder Data	33
18	Main accumulator parameters	35
19	Main cell specification	36
20	SMD Data	37
21	Cell Temperature Monitoring	40
22	AIR data	40
23	AMS Data	43
24	Wire data of the company: Delphi, 35 mm <sup>2</sup>	50
25	Wire data of the company: CnC Tech, 0.326 mm <sup>2</sup>	50
26	Wire data of the company: NTE Electronics 0.0005064 in <sup>2</sup>	51
27	Wire data of the company: CnC Tech 0.0005064 in <sup>2</sup>	51
28	Wire data of the company: AWC Allied Wire, 0.0005064 in <sup>2</sup>	51
29	Wire data of the company: Hosa Tech, 0.005125 in <sup>2</sup>	51
30	Charger data	54
31	Switches and devices in the shutdown circuit	60
32	Shutdown circuit current draw	60
33	Parameters of the IMD	64
34	GLV System Data	67



## List of Abbreviations

- AIR- Accumulator Isolation Relay
- AMS- Accumulator Management System
- GLV- Grounded Low-Voltage
- IMD- Insulation Monitoring Device
- SMD- Segment Maintenance Disconnect
- MSD- Manual Service Disconnect
- TS- Tractive System
- TSEL- Tractive System Energized Light
- TSMP- Tractive System Measurement Point
- TSV- Tractive System Voltage
- TSVP- Tractive System Voltage Present
- CONN- Main accumulator connector
- NDA- Non-Disclosure Agreement

# 1 Vehicle Overview

Person primarily responsible for this section:

Name: Lisa Hachmann  
e-mail: Lisa.Hachmann@students.olin.edu

Check the appropriate boxes:

Vehicle is:

- New (built on an entirely new frame)
- New, but built on a pre-existing frame (FSAE, FS, FH electric-only, etc.)
- Updated from a previous year vehicle

Architecture:

- Hybrid
- Hybrid in Progress (HIP)
- Electric Only

Drive:

- Front Wheel
- Rear Wheel
- All-wheel

Regenerative Braking:

- Front Wheels
- Rear Wheels
- All-wheels
- None

*Provide a brief, concise description of the vehicles main electrical systems including tractive system, accumulator, hybrid type (series or parallel) and method of mechanical coupling to wheels. Describe any innovative or unusual aspects of the design.*

We have designed an all-electric car powered by 2 Zero Motorcycles Z-Force brushless DC motors coupled to Sevcon Gen 4 Size 4 motor controllers. The motors independently drive the rear wheels through two single speed chain reductions. Independent drive allows us to implement a virtual differential drive mode and eventually torque vectoring, which is a project for the future and will not be implemented on the vehicle this year. The accumulator comprises 12 Nissan Leaf modules in series, which in total provides 96.4V and 65Ah of capacity. The car communicates across a CAN-Bus system, simplifying wiring substantially.

*Include the following figures:*

- *Figure 1 – an electrical system block diagram showing all major parts associated with the tractive-system. (Not detailed wiring).*
- *Figure 2 – Drawings or photographs showing the vehicle from the front, top, and side*
- *Figure 3 – A wiring diagram superimposed on a top view of the vehicle showing the locations of all major TS components and the routing of TS wiring.*
- *Figure 4 – Include a complete TSV wiring schematic per FH Rule S4.4.1 showing connections between all TS components. This should include accumulator cells, AIRs, SMDs, motor controller, motor, pre-charge and discharge circuits, AMD, IMD, charging port and any other TS connections.*  
*NOTE: Figure 4 is the most important diagram in the ESF*

Please note that the figure numbers in our document do not correspond to the specified numbering above (Figure 2 comprises 3 figures: top, front, side view of the vehicle).

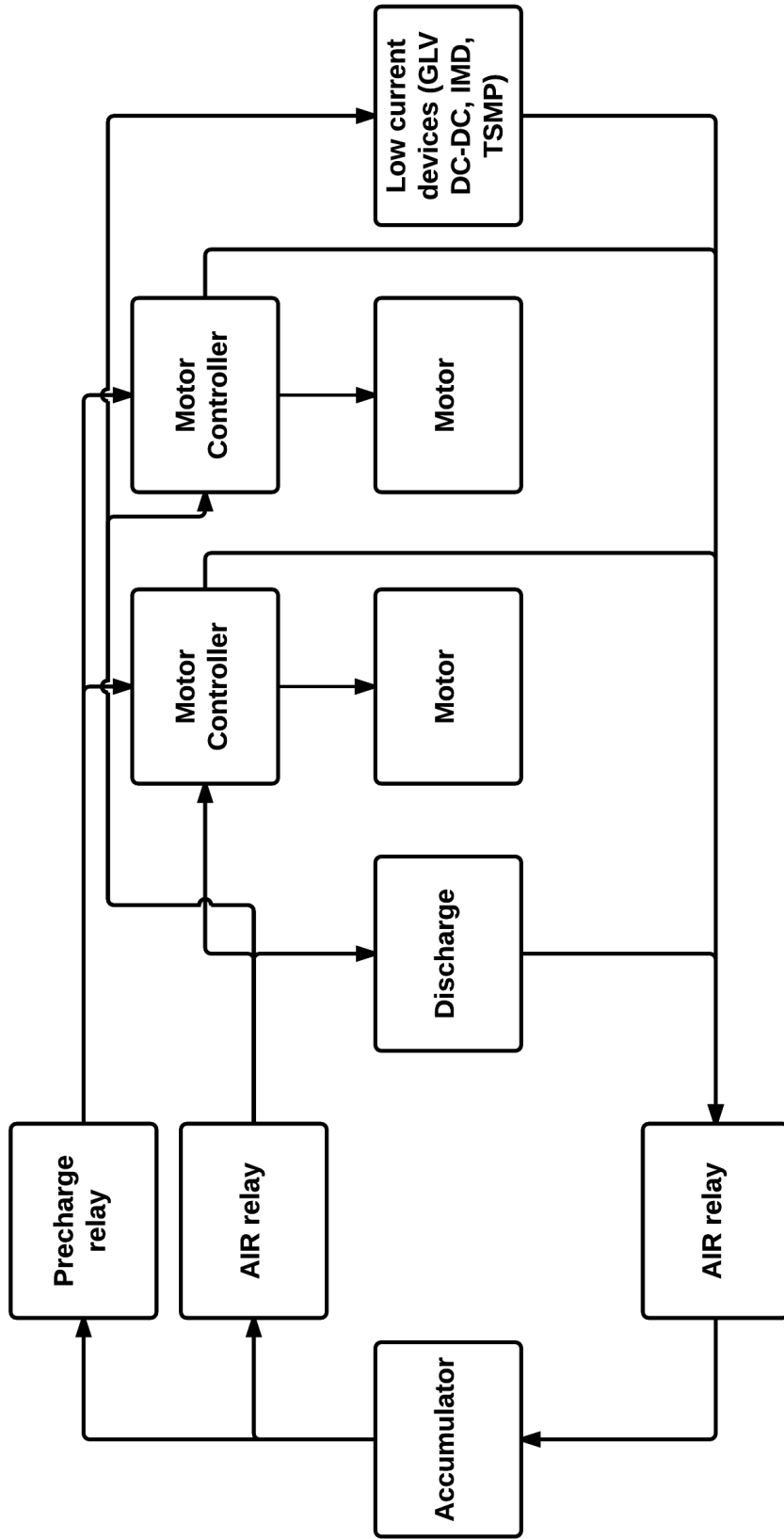

Figure 1: Tractive System Block Diagram

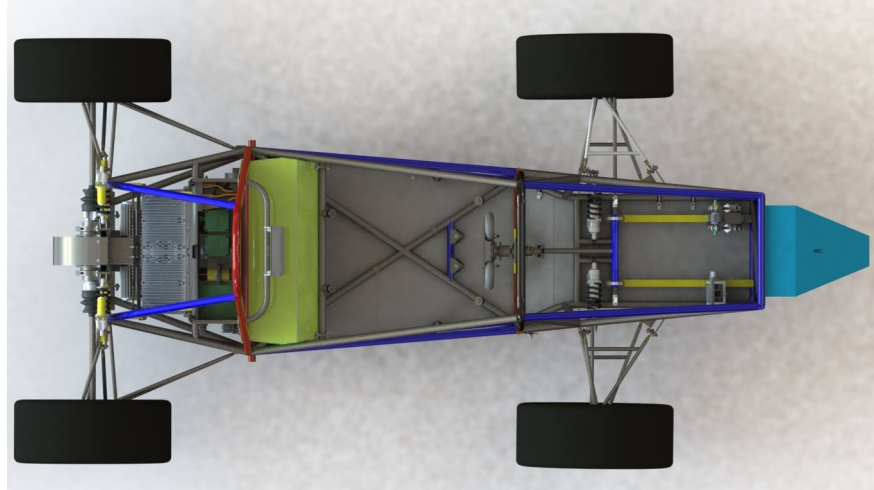

Figure 2: Full Vehicle, Top View



Figure 3: Full Vehicle, Side View

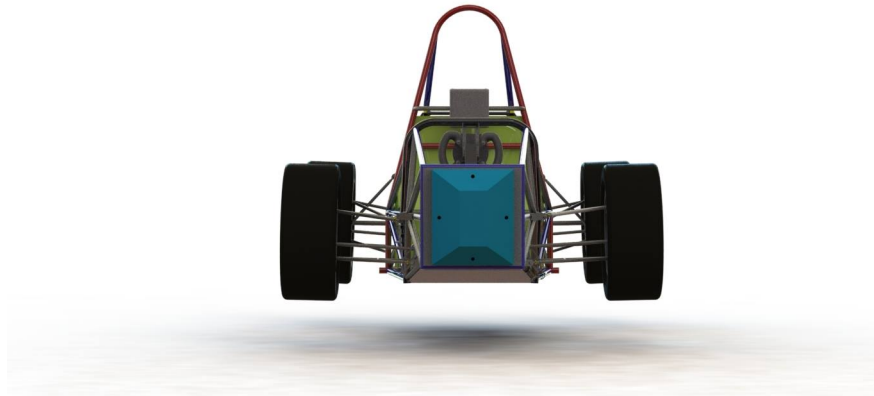

Figure 4: Full Vehicle, Front View



Fill in the following table:

Item	Data
Nominal Tractive System Voltage (TSV)	90 VDC
Max. TSV (typically this is during charging)	98.4 VDC
Control System voltage (GLV)	13.5 VDC
Total Accumulator capacity (Wh)	4680 Wh
Accumulator Type	Li-ion
Number of electric motors, total	2
Are wheel motors used?	No

Table 1: General Electrical System Parameters

## 2 Cables, Fusing & Grounding

Person primarily responsible for this section:

Name: Lisa J. Hachmann  
 e-mail: Lisa.Hachmann@students.olin.edu

### 2.1 Fusing and Overcurrent Protection

List TS and GLV fuse (or circuit breaker) data, and where used

Mfg.	Fuse Part Number	Cont. Rating (A)	DC Voltage Rating	DC Interrupt Rating (A)	Where Used
Bel Fuse	CIQ 3	3A	63V	63V DC@50A	Each input to AMS voltage reading
Ferraz Shawmut	A15QS7-2	7A	150V	100,000	Keyswitch pin activating precharge
Bussman	LPJ-175SP	175A	300V	20,000	TS+ before motor controllers
Littelfuse	F3169CT-ND	1A	125V	300A@125VDC	TS+ and TS- low current components, lights' DC-DC converter, GLV DC-DC converter
Littelfuse	MINI2BP	2A	32 V	1000A @ 32 VD	12V power, Shutdown circuit.
Littelfuse	MINI5BP	5A	32 V	1000A @ 32 VD	GLV system
Bel Fuse	OZCK0050FF2E	0.5A	6V	PTC Resettable	5V CAN circuit
Bussmann/Eaton	BK/SC-20	20A	170 V	10kA Vdc	Charging input to battery

Table 2: Fuse Table

There is a 1A fuse on both the TS+ and TS- lines (20 AWG), protecting the GLV system by being in front of the DC-DC converter and protecting the TS sensing lines for the IMD, TSEL, accumulator indicator and TSMPs. For its connection in the tractive system, please see figure 57 and for its connection in the glv system, please see figure 68.

### 2.2 Component Fusing

List major components (e.g., motor controller, dc-dc converter) and data sheet max fuse rating. Ensure that the rating of the fuse used is less than the maximum value for the component.



Component	Fuse Part Number	Max Fuse Rating	Installed Fuse Rating	Notes
Motor Controllers	LPJ175SP	190 A (for 2AWG)	175A	Fused before motor controllers in parallel
AMS inputs (x28)	CIQ 3	4A (for traces)	3A	Each input fused separately
GLV System	MIN5BP	7A (for 22AWG)	5A	
GLV 12V	MIN2BP	7A (for 22AWG, traces)	2A	
Shutdown circuit	MIN2BP	7A (for 22AWG, traces)	2A	
5V CAN circuit	0ZCK0050FF2E	0.5A	0.5A	
Lights DC-DC converter, TSMPs, GLV DC-DC converter, and IMD	F3169CT-ND	7A (for 22 AWG)	0.5A	Protects all TS low current components
Keyswitch input to Motor Controller	A15QS7-2	7A (for motor controller LV input)	7A	
Battery Input (charging)	BK/SC-20	For battery cells, charging	NDA	

Table 3: Component Fuse Ratings

## 2.3 System Wire Tables

List wires and cables used in the Tractive System and the GLV system - wires protected by a fuse of 1 A or less may be omitted. Cable capacity is the value from FH Rules Appendix E (Wire Current Capacity). A revised version of Appendix E that includes metric wire sizes is available at the FH web site. Show available fault current and how calculated. Available fault current can be calculated from  $FaultCurrent = V_{source} / (R_{source} + R_{wiring})$

Mfg	Part No.	Size AWG	Insulation Type	Voltage Rating	Temp. Rating	Capacitance (per FB)	Fuse Part #	Fuse Cont. A.	Fuse Interrupting Rating A	Available Fault Current	Where used & how current is calculated
Prestolite	Not listed U1-0310-2070	2 AWG (33.3 mm <sup>2</sup> )	EPDM Single layer	8 kVAC	125 C	100 A	LF2-175P	175	20/000	41152 A	Motor Controller
Delphi	Not listed	35 mm <sup>2</sup>	Dual (unlabeled)	600 V	150 C	190 A	Series with above fuse	See above	See above	41152 A	Accumulator to HVO Accumulator
Wichang	Unknown	See below	XLPE	300V	150 C	Motor leads	Series with above fuse	See above	See above	41152 A	Accumulator to HVO Accumulator
GM Tech	CNSTR-30-ND	20 AWG	Silicone Rubber	300V	157 C	10 A	MRS3P	5A	20 F 5	25A	See description
DELTA Electronics	C12235-110	22 AWG	CSP-207, COBLEN (PVC)	250V	85 C	2 A	31024P	5A	25/25	25A	See description
Valon	20694 f1	22 AWG	SR-PVC	300V	80 C	7 A	See above	See above	See above	See description	between PCBs
NFE Electronics	WH22-02-26	22 AWG	PVC	300V	102C	7 A	See above	See above	See above	See description	Accumulator to current wiring and GKA wiring
AVC DirectWire	AW-1100-100F	22 AWG	PVC	300V	102C	7 A	See above	See above	See above	See description	Accumulator to current wiring and GKA wiring
AVC DirectWire	AW-1100-100F	22 AWG	PVC	300V	102C	7 A	See above	See above	See above	See description	Accumulator to current wiring and GKA wiring
Mem. Tech	Speaker Cable EP AWG 12 DFC	12 AWG	PVC	125 V	102C	40A	914BR/SC/20	20A	10A, 7.5	10A, 7.5	See description

Table 4: System wire table

The motor leads are permanently attached by the manufacturer, and are OEM. The width of the motor lead with insulation (other measurements cannot be taken) is 0.45 inch, so we believe it to be of at least 2 AWG. The fault current for the motor to motor controller wiring (Prestolite), is calculated as follows (using FH-supplied formula):

$$\text{Fault Current} = \frac{V_{source}}{R_{source} + R_{wiring}} \quad (1)$$

$$\text{Fault Current} = \frac{100}{0.00149\Omega + 0.00094\Omega} \quad (2)$$

$$\text{Fault Current} = 41152A \quad (3)$$

The fault current for the accumulator to motor controller wiring (Delphi), is calculated as follows (using FH-supplied formula):

$$\text{Fault Current} = \frac{V_{source}}{R_{source} + R_{wiring}} \quad (4)$$

$$\text{Fault Current} = \frac{100}{0.00149\Omega + 0.00145\Omega} \quad (5)$$

$$\text{Fault Current} = 34013A \quad (6)$$

The fault current for the GLV system is restricted by the DC-DC converter supplying power to the GLV system. The DC-DC converter can only output 25A, and will restrict any fault current to 25A.

The fault current for the charging system is restricted by the charger for the batteries. The charger can only output 17A, and will restrict any fault current to 17A.

## 2.4 Grounding System

*Describe how you keep the resistances between accessible components below the required levels as defined in FH Rules EV4.3. If wire is used for ground bonding, state the AWG or mm<sup>2</sup> of the wire*

The chassis is used as GLV ground. This ground is established at the side panel mount holding many of the shutdown components and the TSMP's. All mechanical systems in the vehicle, such as the accumulator, drivers seat, and pedal box, achieve low resistance to ground because they are either welded directly to the chassis, or fastened using uncoated, conductive metal fasteners. Electrical systems that are satellite to the main panel mount that need to establish a connection to ground for sense purposes are grounded to the chassis using ring terminals. Ring terminals can be included in the bolt stack up of mechanical systems to ensure a secure connection to ground that is positively retained with a lock nut. All wires used for ground bonding will be 16 AWG. During charging, there will be a green 16 AWG wire connecting the GLV system to earth ground.

## 2.5 Conductive Panel Grounding

*If carbon fiber or coated conductive panels are used in your design, describe the fabrication methods used to ensure point to point resistances that comply with EV4.3.2. Describe results of measurements made per EV4.3.3.*

We are not using CFRP or conductive materials in our vehicle.

## 3 Isolation and Insulation

Person primarily responsible for this section:

Name:	Lisa Hachmann
e-mail:	<u>Lisa.Hachmann@students.olin.edu</u>

### 3.1 Separation of Tractive System and Grounded Low Voltage System

*Describe how the TS and GLV systems are physically separated (EV4.1). Add CAD drawings or photographs of how TS and GLV are segregated in key areas of the electrical system.*

*List all electrical circuit boards designed by team that contain TS and GLV voltage in the following table.*

Device/PCB	TS Voltage Present	Minimum Spacing mm	Thru Air or Over surface	Notes
AIR Control Board (Precharge, Discharge, Lights, AMS relays, etc)	100 V	6.4mm	Over Surface	
Accumulator Management System (x4)	22.5V	6.4mm	Over surface	1 AMS per segment, each segment nominally 22.5V
Side Panel CAN node (Ready to drive sound, TSMP)	100V	6.4mm	Over Surface	
Motor Controller Isolation	100 V	6.4mm	Over surface	

Table 5: PCB Spacings

Add a figure (board layout drawing) for each team-designed PCB showing that spacings comply with EV4.1.8.

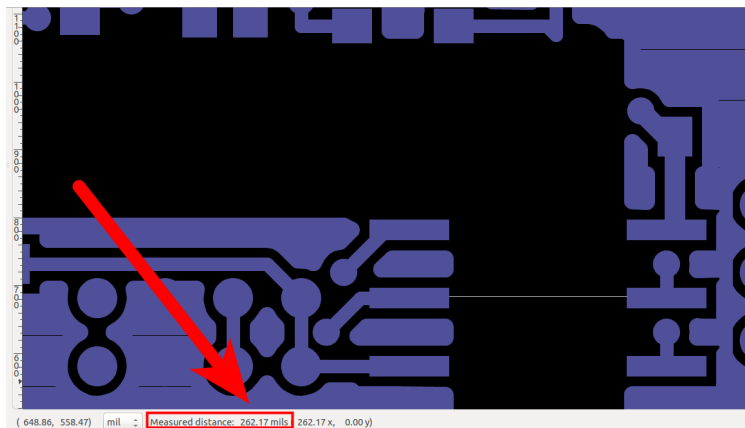

Figure 6: Capture of the separation on each AMS board between TS and GLV power on the top copper (262 mil)

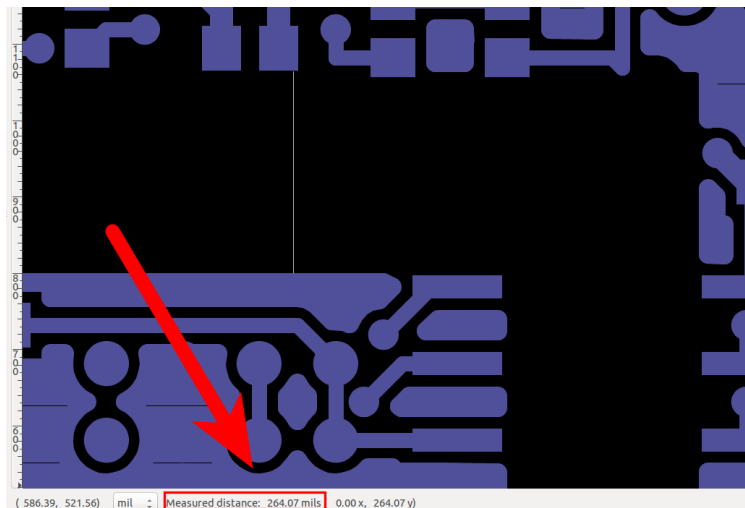

Figure 7: Capture of the separation on each AMS board between TS and GLV power on the top copper (264 mil)

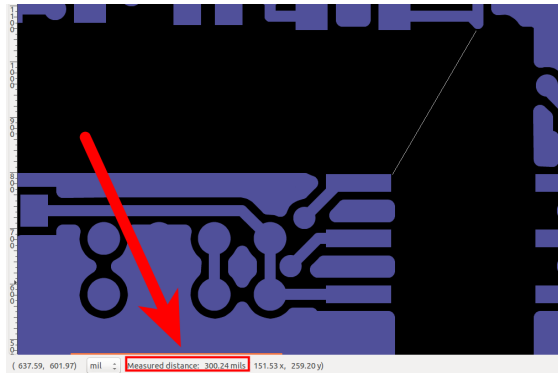

Figure 8: Capture of the separation on each AMS board between TS and GLV power on the top copper (300 mil)

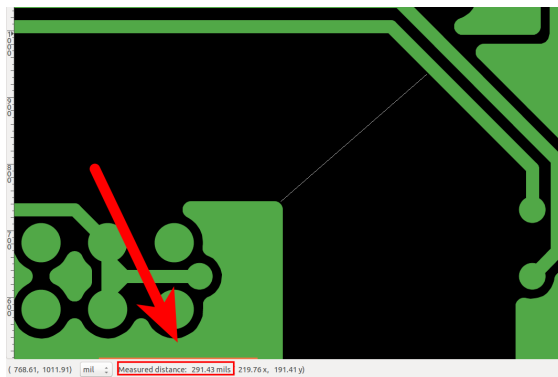

Figure 9: Capture of the separation on each AMS board between TS and GLV power on the bottom copper(291 mil)

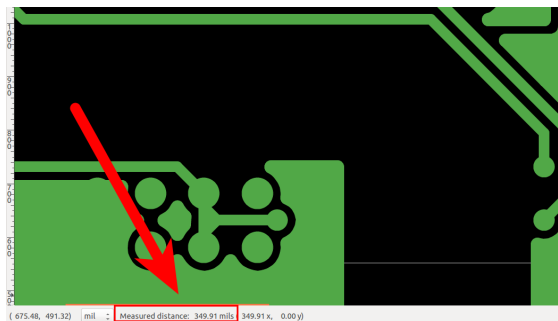

Figure 10: Capture of the separation on each AMS board between TS and GLV power on the bottom copper (349 mil)

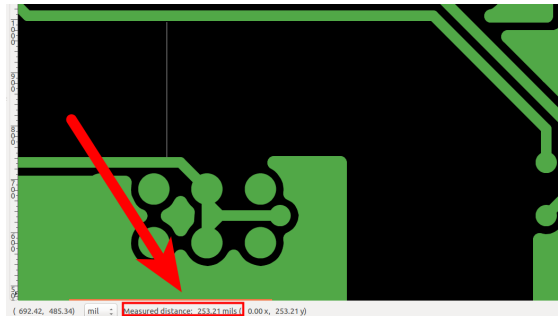

Figure 11: Capture of the separation on each AMS board between TS and GLV power on the bottom copper (253 mil)

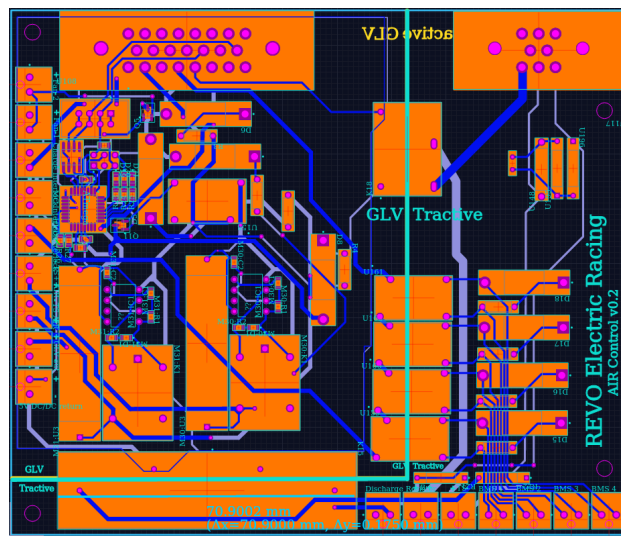

Figure 12: AIR control board, with the bright blue line denoting the separation between the TS and GLV voltage. The smallest separation is 8.5 mm (over surface)

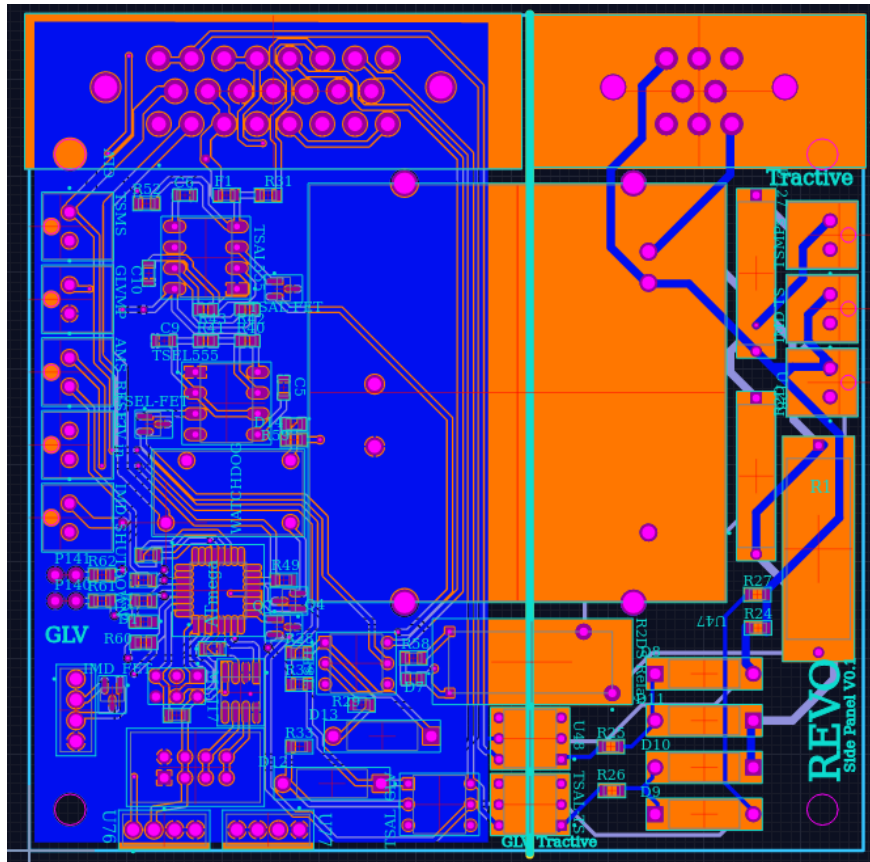

Figure 13: Side Panel board, with the bright blue line denoting the separation between the TS and GLV voltage. The smallest separation is 1/4 in (over surface)

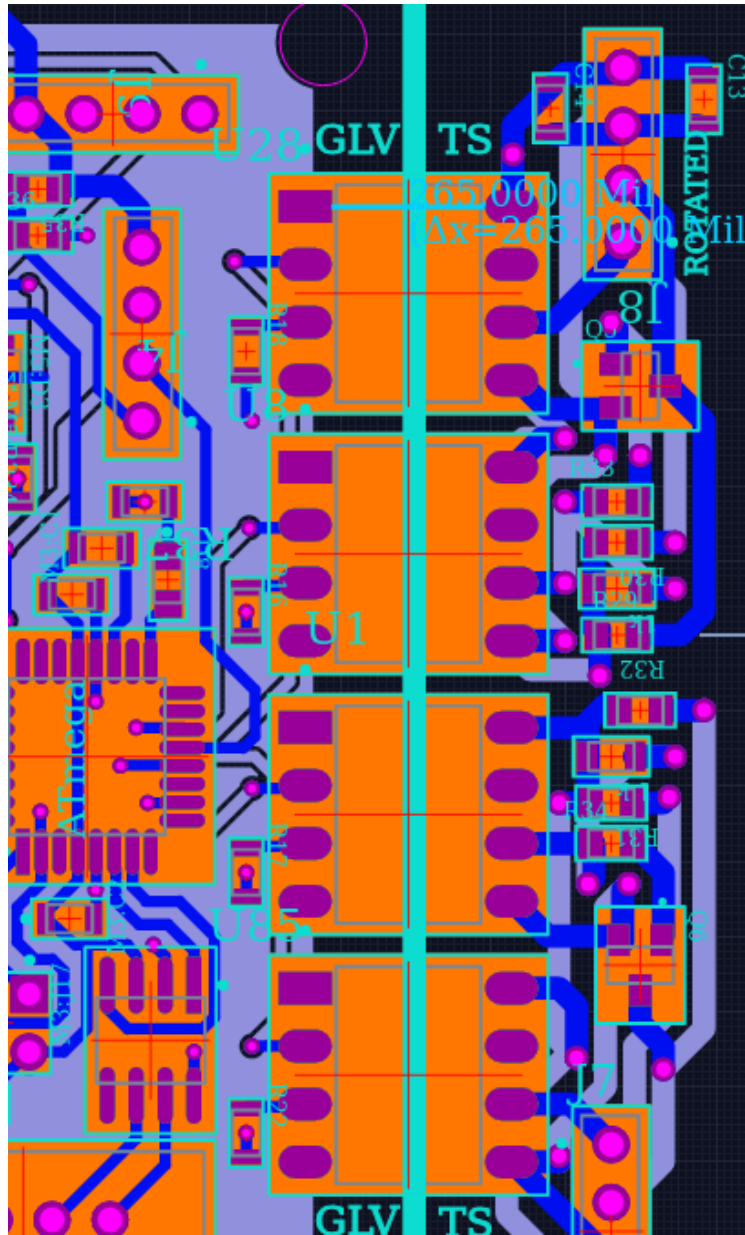

Figure 14: Motor Controller Isolation board, which has a bright blue line denoting the separation between the TS and GLV voltage. The spacing is 6.731 mm. consistently (over surface)

*List all purchased components with both TS and GLV connections (at min motor controller and AMS).*



Component	Isolation method	Link to Document Describing Isolation	Notes
Precharge relay	Galvanic (relay)	<a href="#">Click here</a>	
Discharge relay	Galvanic (relay)	<a href="#">Click Here</a>	
GLV DC-DC converter	Not listed	<a href="#">Click Here</a>	
Lights DC-DC converter	Not listed: Isolation test at 5000V	<a href="#">Click Here</a>	
Ready to drive relay	Galvanic (relay)	<a href="#">Click Here</a>	
AMS relay x4	Galvanic (relay)	<a href="#">Click Here</a>	
Photorelay mosfet	Galvanic (Photorelay)	<a href="#">Click Here</a>	
Isolated CAN Transceiver	Galvanic	<a href="#">Click Here</a>	
BSPD Relay	Galvanic (relay)	<a href="#">Click Here</a>	

Table 6: Purchased Components - Isolation Data

### 3.2 Isolation and Insulation

Provide a list of containers that have TS and GLV wiring in them. If a barrier is used rather than spacing, identify barrier material used (reference Table 7- Insulating Materials).

Container Name	Segregation by Spacing (Y or N)	How is spacing maintained?	Actual Measured Spacing (mm)	Alt Barrier Material P/N	Notes
Accumulator Container	Y	Kevlar reinforced nylon cable clips and cable ties	Accumulator is in assembly so measured distance is unavailable.	McMaster 8667K55 (Garolite)	Garolite is also used as the barrier between segments, TS fuse and AIRs
Motor controller housing	Y	Kevlar reinforced nylon cable clips and cable ties	Housing is in assembly so measured distance is unavailable	Nomex wire tubing McMaster 8798K32	

Table 7: List of Containers with TS and GLV wiring

List all insulating barrier materials used to meet the requirements of EV1.3 or EV4.1.5

Insulating Material / Part Number	UL Recognized ?	Rated Temperature °C	Thickness mm	Notes
N/A	N/A	N/A	N/A	N/A

Table 8: Insulating Materials

### 3.3 Conduit

List different types of conduit used in the design. Specify location and if manufacturer's standard fittings are used. Note Virtual Accumulator Housing FH Rules EV3.3.1 requires METALLIC type LFMC. Describe how the conduit is anchored if standard fittings are not used.

Conduit Type	MFR	Part Number	Diameter	Standard fittings	Location/Use
PVC Nylon PVC	N/A (McMaster)	8465K23	3/4" trade size	Y	Motor to Motor controller (x2)

Table 9: Conduit Data

*Is all conduit contained within the vehicle Surface Envelope per EV4.2.1? (Y or N).*

Yes, all conduit is contained within the vehicle surface envelope per EV4.2.1.

*Does all conduit comply with EV4.5.10? (Y or N).*

Yes all conduit complies with EV4.5.10.

### 3.4 Shielded Dual-Insulated Cable

*If shielded, dual-insulated cable per EV4.5.8 used in the vehicle, provide specifications and where used:*

MFR	Part Number	Cross section	Shielded ground at	Location/Use
Delphi	Unknown	35 mm <sup>2</sup>	Y	Accumulator to HVD, Accumulator to Motor controllers (x2)

Table 10: Shielded Dual Insulated Cable Data

The Delphi shielded cable is being provided by General Motors, and we are still trying to get the part number at this time. It is rated for 125 °C and 600V.

### 3.5 Firewall(s)

*Describe the concept, layer structure and the materials used for the firewalls. Describe how all firewall requirements in FH Rules T4.5.1 are satisfied. Show how the low resistance connection to chassis ground is achieved.*

#### Description/Materials

The firewall is constructed of two layers. The layer facing the tractive system is 1.5 mm aluminum sheet metal, with a chamfered edge. The second layer facing the cockpit is 1/8 in. Flame-Retardant Multipurpose Garolite (G-10/FR4). The assembly is fastened together using sheet metal rivets. The chassis has welded sheet metal tabs that fasten to the firewall with bolts and positively retained nuts. Because the firewall is fastened to the chassis using conductive fasteners, it is connected to GLVS ground.

All high voltage and high temperature systems are contained in the rear of the vehicle, so only one firewall will be used. There are GLV systems in the dashboard and pedal box. A small grommeted hole will be made in the firewall for GLV wiring only.

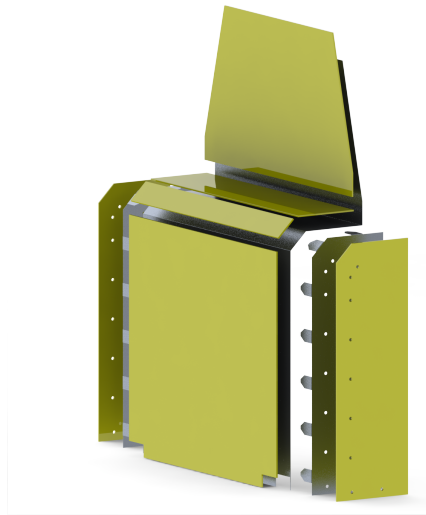

Figure 15: Exploded view of the firewall

#### Position in Car

*Provide CAD-rendering or photographs showing the location of the firewall(s)*

The firewall is located between the driver and the accumulator, to protect the driver from the TS. Figure 16 shows the position with the driver seat. The top corner of the extruded part of the firewall is chamfered in order to protect the driver and will also be covered with padding.



Figure 16: Photograph of the installed firewall's position in the car

## 4 Electric Tractive System

Person primarily responsible for this section:

Name: Lisa J. Hachmann  
e-mail: Lisa.Hachmann@students.olin.edu

## 4.1 Motor(s)

*Describe the motor(s) used and reason for this particular choice. Add additional tables if multiple motor types are used*

The motors used are Zero Motorcycles Z-Force 75-5 brushless DC motors, which are manufactured and used by Zero Motorcycles in their production units. We have an established sponsorship with Zero Motorcycles, which is the primary reason for our motor selection. The motors are paired to two Sevcon Gen 4 Size 4 motor controllers, which are also used in Zero's production units.

Manufacturer and Model	Zero Motorcycles 75-5 Series, Model # 30-0534
Motor type	DC Brushless
Number of motors of this type used	2
Nominal motor voltage (Vdc)	102 Vdc
Nominal/Peak motor current (A)	Nom: 250 / Peak: 420
Nominal/Peak motor power	Nom: 24.9 / Peak: 41.8
Motor wiring - conductor size and type	$\geq 2$ AWG

Table 11: Motor Data

The motor wiring (Weicheng) is permanently attached and grommetted to the motor casing. The wire gauge was measured to be 0.45 inches with single-layer XLPE insulation, so we believe the wire gauge to be greater to or equal to 2 AWG. 2AWG wire from Panduit with single-layer thermoplastic insulation is specified to have an outside diameter of 0.420 inches, less than the measured outside diameter of the motor leads.

*Provide calculations for currents and voltages. State how this relates to the choice of cables and connectors used.*

The choice of cables and connectors were made in reverse from the motor's maximum current draw. With the maximum current draw for 10 seconds being 660A (at 100V) for both motors combined, we specified the smallest fuse rated for that amount of current draw: 175A continuous. For a 175A fuse, the smallest wire gauge specified from Appendix E of the rules is 2 AWG (rated up to 190A). All wire gauges and connectors specified for the high current path of the motors and/or accumulator are equal to or greater than 2 AWG.

## 4.2 Motor Controller

*Describe the motor controller(s) used and reason for this particular choice. Add additional tables if multiple motor controller types are used.*

The motor controllers were chosen because they pair well with the chosen motors, and they can be controlled by either CAN or analog signals.

*If the answer to the last question is NO, how to you intend to comply with rule EV2.3 (an external isolator is acceptable)*

*Provide calculations for currents and voltages. State how this relates to the choice of cables and connectors used.*

Please see section 4.1, as the same choices were made between motors and motor controllers.

## 4.3 Tractive System Measurement Points (TSMP)

*The TSMP must comply with FH Rule EV4.4. Describe the TSMP housing and location. Describe TSMP electrical connection point.*

The TSMPs are located on the motor controller housing, which is a polycarbonate, PLA and nylon enclosure that is located in the rear right side of the car, behind the main hoop. This housing also contains most of the shutdown components. Electrically, it is connected to the TS+ and TS- power lines (past the AIR's,

Manufacturer and Model	Sevcon Size 4 Gen 4
Number of controllers of this type used	2
Maximum Input voltage (Vdc)	116 VDC
Nominal Input current (A)	350 A
Max Input Fuse (A) per Mfr.	355 A
Output Voltage (Vdc)	Same as input voltage
Isolation rating between GLV (power supply or control inputs) and TS connections	None
Is the accelerator galvanically isolated from the Tractive system per EV2.3	No

Table 12: Motor Controller Data

in a separate connector and wiring bundle), in parallel to the motors but fused to 1A on both the TS+ and TS- lines. This fusing was cleared in Ticket #1193, as we have a fuse protecting the wiring before the TSMPs. The housing includes all TS voltage components besides those in the accumulator and HVD. Please see Figure 5 for the schematic in the larger context, as Figure 17 is a schematic focused on the TSMPs, with and without the multimeter. The TSMPs are mounted on the side panel PCB.

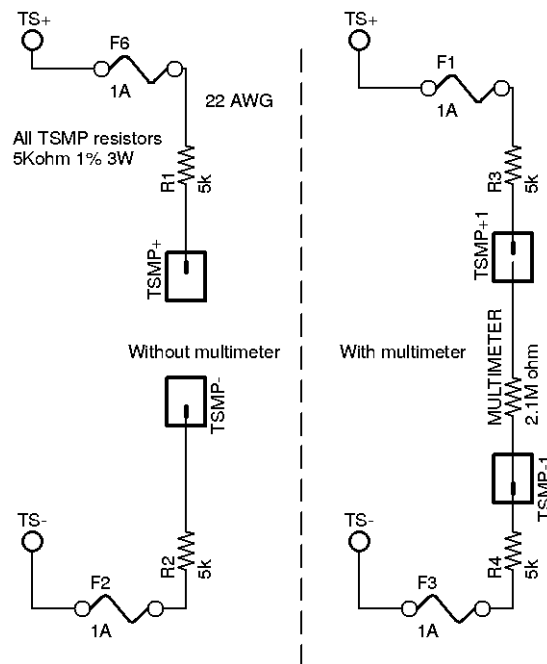

Figure 17: TSMP Schematic, with and without multimeter probes.

The TSMP resistors follow the following calculations:

$$V = I * R \tag{7}$$

$$100V = I * 10,000\Omega \tag{8}$$

$$I = 0.01A \tag{9}$$

$$P = I * V \tag{10}$$

$$P = 0.01I * 100VV \tag{11}$$

$$P = 1W \tag{12}$$

Therefore, a 1W, 5kΩresistor will be placed before each TSMP banana jack. The resistor will be on a small, separate PCB or break out board that only contains the resistors to the TSMPs. This PCB does not have a finished design yet, but will be housed such that it is insulated from all adjacent conductive materials.

Another worst case scenario that could occur at the measuring points is a short between the TS and GLV systems over the banana jacks, again by operator error. In this scenario, the IMD will open the shutdown circuit.

Figure 61 shows the housing that the TSMPs are on. There are covers on top of the banana jacks, and the TSMPs are directly on side panel PCB.

The TSMP banana jacks are 72930-2 and 72930-0 Pomona Electronics 4 mm banana jacks (red and black, respectively). The TSMP resistors are Vishay Dale ALSR035K000FE12 (manufacturer’s part number), rated for 122V and part of the ALSR series.

TSMP Output Protection Resistor Value	5 kΩ
Resistor Voltage Rating	122V
Resistor Power Rating	3W

Table 13: TSMP Resistor Data

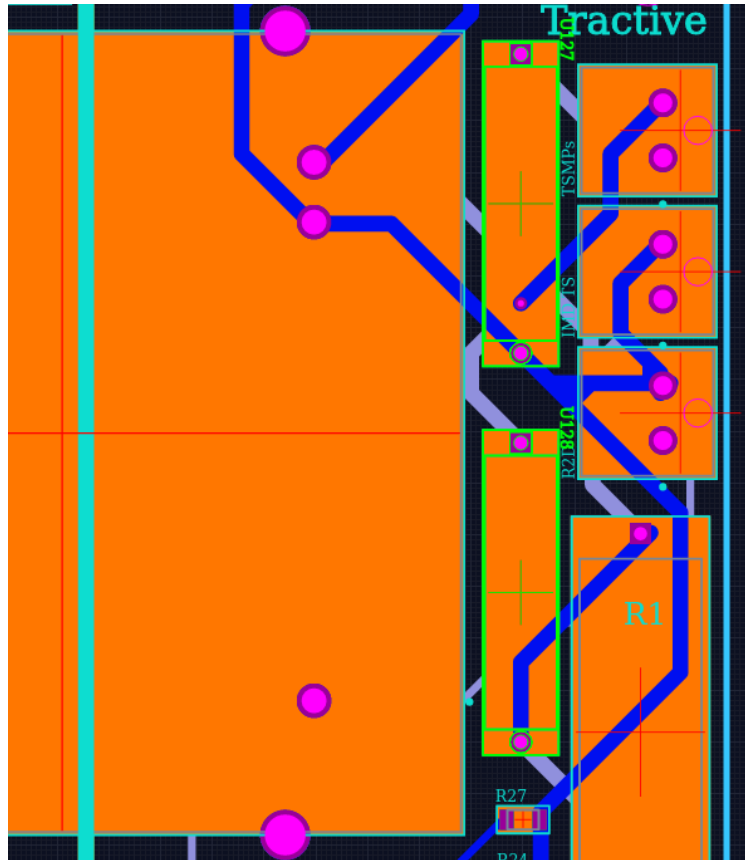

Figure 18: Close up of TSMP pcb footprints (highlighted in green) on the side panel PCB. Note the bright cyan line of isolation between the GLV and TS.

#### 4.4 Pre-Charge System

*Describe your design for the pre-charge circuitry. Describe wiring, connectors and cables used.*

- Include a schematic of the pre-charge circuit
- Include a plot of calculated TS Voltage vs. time
- Include a plot of calculated TS Voltage vs. time
- Include a plot of resistor power vs time

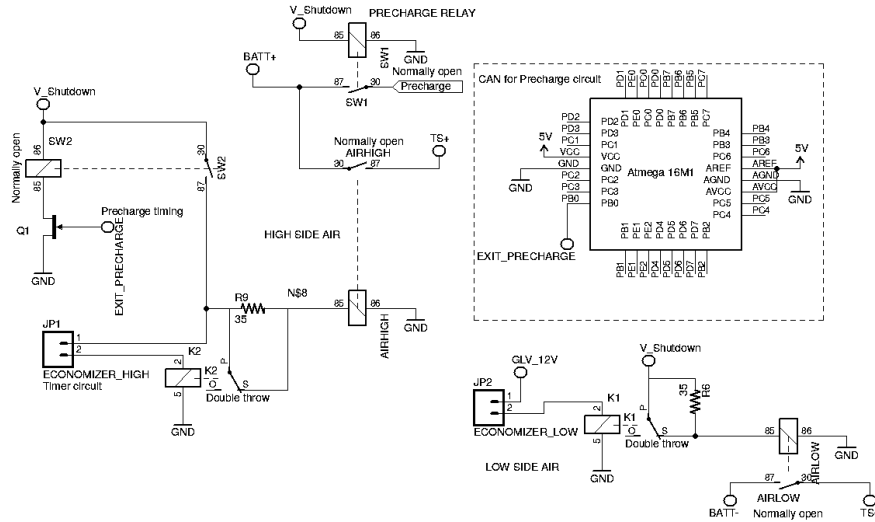

Figure 19: Precharge System Schematic

Ticket #1209 stated compliance of the internal precharge system of the Sevcon motor controller instead of a separate precharge system consisting of a relay and resistor.

Once the shutdown circuit is closed, it will immediately power the coils of the normally closed discharge relay, the normally open precharge relay (found on the top in figure 19, connecting BATT+ to the precharge tag), and the normally open TS- AIR. This opens the discharge relay, and closes the precharge relay and TS- AIR. Instead of connecting Batt+ to TS+ through a current limiting resistor, the precharge relay connects B+ to the key switch terminal on each of the Sevcon motor controllers. When powered by their key switch terminals, the motor controllers charge their internal capacitors up to around 50V for 0.5 seconds, then up to 90V (or another specified voltage) for 0.1 seconds before signaling through the CAN system that the precharge is complete. This CAN message causes a node in the battery to allow the shutdown circuit to close the TS+ AIR.

In figure 20, the voltage of a test setup of the pre-charge system internal to the motor controller was measured. Because there is no resistor other than the motor controller, the current and power could not be calculated and/or graphed. As discussed above, the function describing the pre-charge is stepwise.

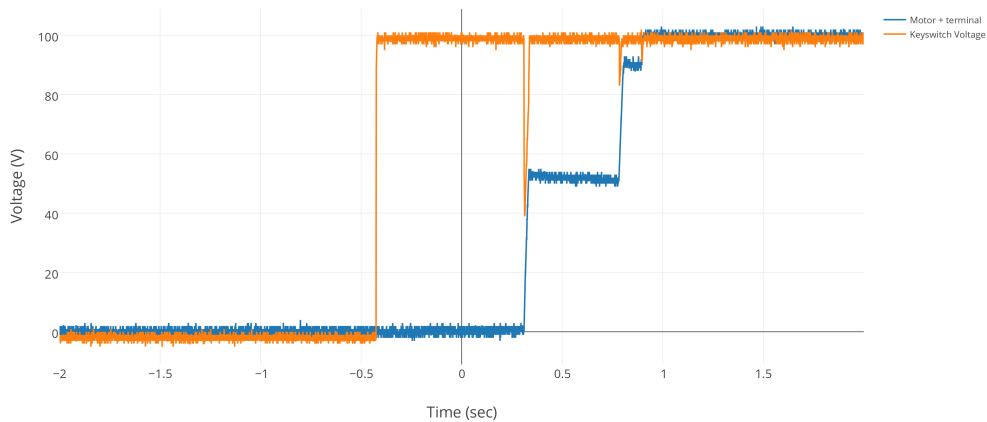

Figure 20: Measured Precharge voltage for both the motor and the keyswitch activation

Provide the following information:



Because of our use of the motor controller’s internal precharge functionality, the vehicle has no separate pre-charge resistor.

Resistor type	N/A
Resistance	N/A $\Omega$
Continuous power rating	N/A W
Overload power rating	N/A W
Voltage rating	N/A V

Table 14: Data for the pre-charge resistor

Relay MFR & Type:	TE Connectivity LEV100 Series
Contact Arrangement	SPST-NO
Continuous DC contact current	100A
Contact voltage rating	900VDC

Table 15: Data of the pre-charge relay

## 4.5 Discharge System

*Describe your concept for the discharge circuitry. Describe wiring, connectors and cables used.*

- Include a schematic of the pre-charge circuit
- Include a plot of calculated TS Voltage vs. time
- Include a plot of calculated “Discharge current” vs. time
- Include a plot of resistor power vs time.

*Provide the following information:*

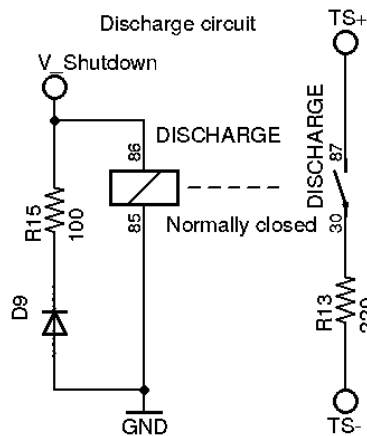

Figure 21: Schematic of the discharge system

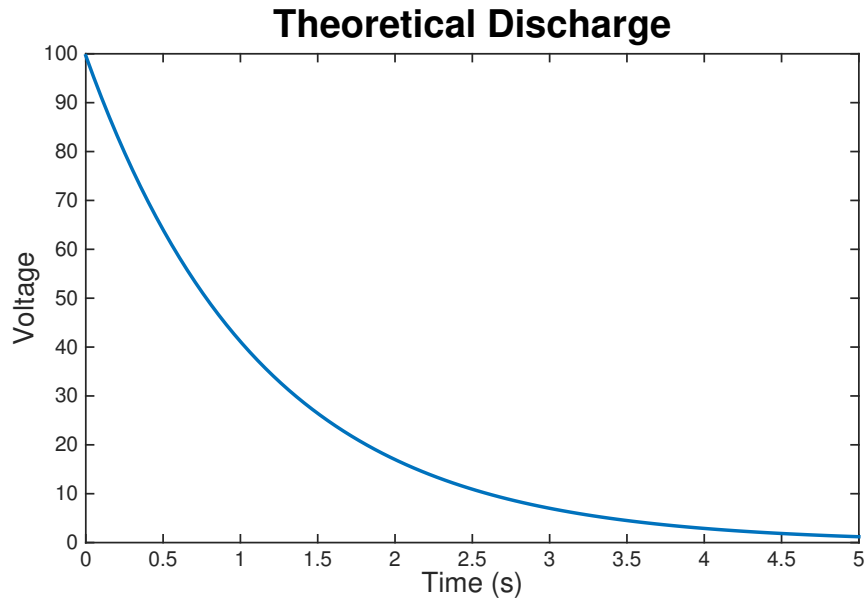

Figure 22: Calculated discharge voltage vs. time

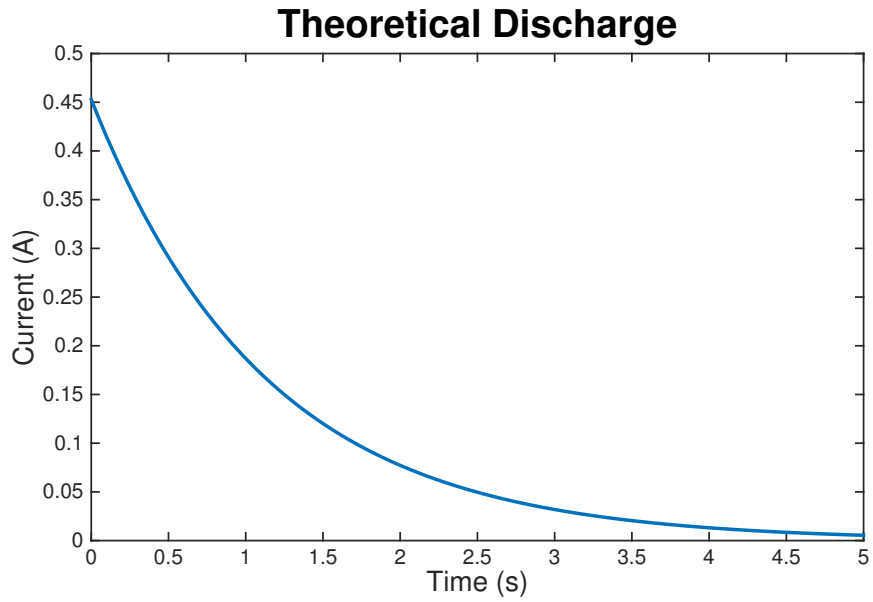

Figure 23: Calculated discharge current vs. time

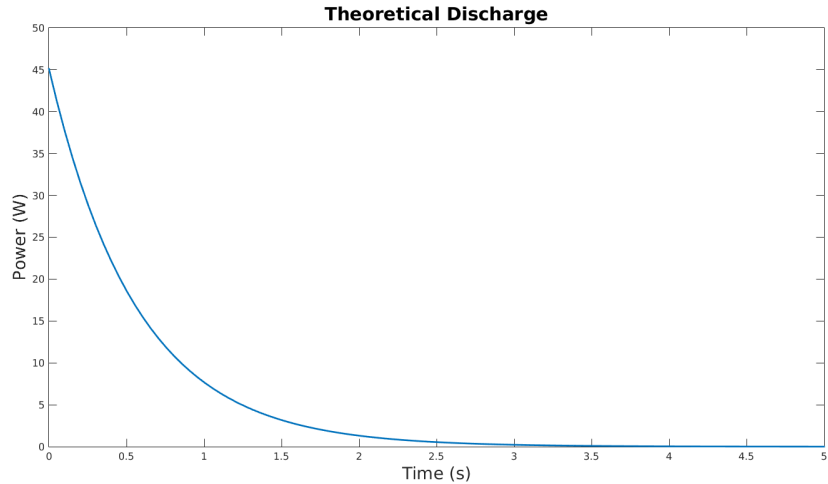

Figure 24: Calculated discharge power vs. time

Resistor Type	Aluminium Housed Wirewound Resistor
Resistance	220 Ω
Continuous power rating	50 W
Overload power rating	Unknown
Voltage rating	Not listed
Maximum expected current	0.45 A
Average current	0.1 A

Table 16: Data of the discharge circuit

The maximum discharge current and power is calculated as follows:

$$V = I * R \tag{13}$$

$$100V = I * 220\Omega \tag{14}$$

$$I = 0.45A \tag{15}$$

$$P = I * V \tag{16}$$

$$P = 0.45 * 100 \tag{17}$$

$$P = 45W \tag{18}$$

Therefore the 50W, 220Ωresistor will be able to handle the power of the discharge circuit continuously, but will only need to handle it for the start of discharge, which itself only lasts 5 seconds.

#### 4.6 High Voltage Disconnect (HVD)

*Describe your design for the HVD and how it is operated, wiring, and location. Describe how your design meets all requirements for EV4.7*

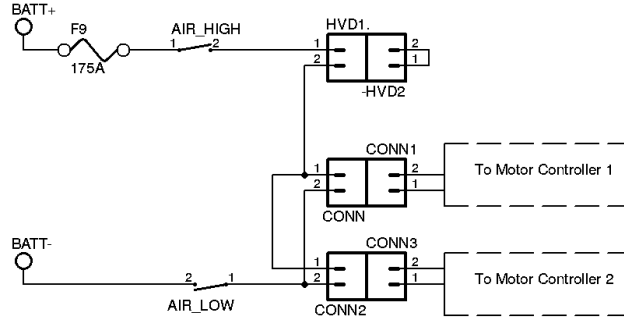

Figure 25: Electrical connections of the HVD

We will be using an Anderson Power Products SB Smart VEH-G12 HVD (P/N 115158G12 Vehicle Side and P/N 115158G11 Outboard Side) as our high voltage disconnect, provided by Zero Motorcycles. The part we have in-hand also has a rubber grip on the outboard side of the HVD, which gives the user a better purchase on the HVD, as shown in Figure 26.

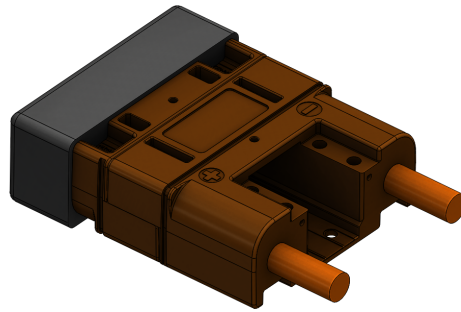

Figure 26: Anderson Power Products SB Smart VEH-G12 HVD

#### 4.7 Accelerator Actuator / Throttle Position Sensor

*Describe the accelerator actuator and throttle position sensor(s) used, describe additional circuitry used to check or condition the signal going to the motor controller. Describe wiring, cables and connectors used. Provide schematics and a description of the method of operation of any team-built signal conditioning electronics. Explain how your design meets all of the requirements of FH Rules IC1.6 and EV2*

Actuator/Encoder MFR and model	Magni-Tec MHR5621
Encoder principle	Dual-Rotary Potentiometer
Output	Analog
Is motor controller accelerator signal isolated from TSV?	No
If no, how will you satisfy rule EV2.3?	Optocoupler

Table 17: Throttle Position Encoder Data

The 2 throttle encoder outputs (2 electrically-separated potentiometers contained within MHR5621) will be sensed through an ATMEGA16M1 input pin, communicating through CAN to the rest of the vehicle. The CAN node will then send it to the motor controller CAN node (with no amplification in any way).

That CAN node will output the same analog signal through an optocoupler to separate it from the GLV system and ground it to the TS system. There will be pull-down resistors on both inputs in order to detect wire-failure for the potentiometer's input. Software will detect whether the potentiometer inputs are within 10% of each other, as well as checking that the potentiometer readings are within the limits of the system. Please see figure 27 for the potentiometer inputs and figure 28 for details on the isolation between the motor controller controller (MCC) PCB Atmega16M1 and the motor controller.

This design meets all rules requirements because the system is galvanically isolated from the motor controller inputs and our system is able to detect all the plausible failure modes of the potentiometer.

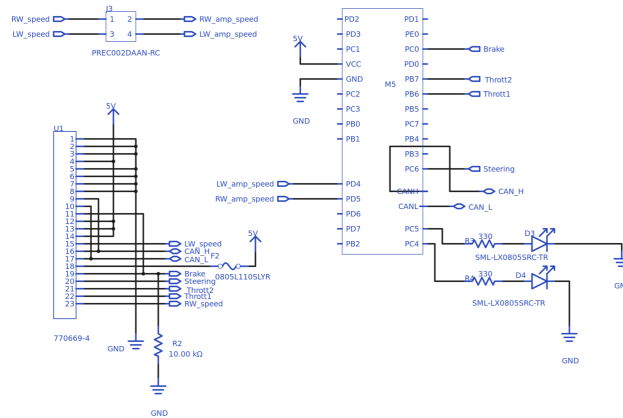

Figure 27: Schematic of the bulkhead, which has potentiometer inputs for throttle

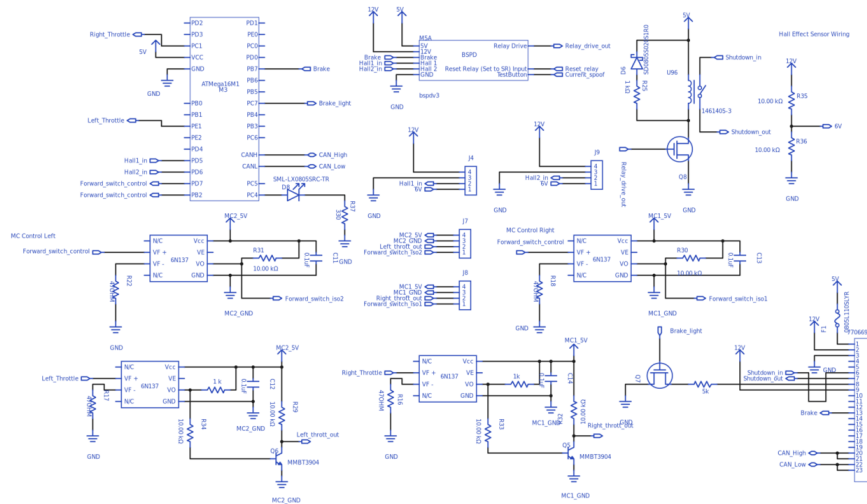

Figure 28: Motor controller controller schematic

#### 4.8 Accelerator / Throttle Position Encoder Error Check

*Describe how the system reacts if an error (e.g. short circuit or open circuit or equivalent) is detected. Describe circuitry used to check or condition the signal going to the motor controller. Describe how failures (e.g. Implausibility, short circuit, open circuit etc.) are detected and how the system reacts if an error is detected. State how you comply with EV2.2*

There are two main errors that need to be considered. Potentiometer input failure, as in a wire being disconnected or an invalid signal, and CAN communication system failure, as in invalid message objects are sent.

In the case of a short or open-circuit for potentiometer input failure, there will be a pull-down resistor which will pull the value read at the input pin to 0V (and in case of a short it will be pulled to 5V). Any reading not in the range of 1V-4V will be considered an error and will be dealt with in software. No throttle command will be sent in this case.

The CAN system is highly resilient and is programmed with error handling as the highest priority. The CAN protocol itself specifies a cyclic redundancy check which ensures that the messages are not corrupted in transmission. Both the Throttle node and MCC node will check the throttle values to ensure that they are in a valid range. If the MCC node does not receive a throttle CAN message for a tenth of a second it will tell the motor controllers to have 0 throttle.

## 5 Accumulator System

Person primarily responsible for this section:

Name:	Lisa Hachmann
e-mail:	Lisa.Hachmann@students.olin.edu

### 5.1 Accumulator Pack

*Provide a narrative design of the accumulator system and complete the following table.*

All cell information listed was recorded from actual measurements. Most manufacturer data is under NDA and restricted until we receive permission to release this information to the Formula Hybrid team. We are allowed to share module capacity (at 2C), nominal voltage, size, weight and energy density. The rest of the numbers given in the following sections will either come from measurements or limits that the team imposes on the batteries, and we have the knowledge that they are safe for our cells.

Maximum Voltage (during charging)	NDA, see below
Nominal Voltage	3.75 VDC (7.5VDC per module)
Total number of cells	48
Cell arrangement	2s2p in one module, 12 modules in series
Are packs commercial or team constructed	Team
Total Capacity (per FH Rules Appendix A)	4.68 kWh
Maximum Segment Capacity	5.265 MJ
Number of Accumulator Segments	4

Table 18: Main accumulator parameters

The maximum voltage that the accumulator will be charged to is 98.4V.

*Describe how pack capacity is calculated. Provide calculation at 2C (0.5 hour) rate? How is capacity derived from manufacturer's data? If so, include discharge data or graph here. Include Peukert calculation if used (See FH Rules Appendix A). Show your segment energy calculations.*

The pack capacity is calculated with the formula given in FH Rules Appendix A as:

$$\text{Capacity} = V_{nom} * A_h * 0.8 \quad (19)$$

$$\text{Capacity} = 90 * 65 * 0.8 \quad (20)$$

$$\text{Capacity} = 4680\text{Wh} \quad (21)$$

$$\text{Capacity} = 4.68\text{kWh} \quad (22)$$

The segment energy is calculated as: Nominal voltage (per module) x Cell AH (per module) x Number of modules x 3.6 kJ (The 80% factor is not applied for this calculation). Each segment is 1/4 of the total accumulator (3 modules, with 12 modules being the total).

$$\text{Seg Energy} = V_{nom} * \text{Number of Cells} * \text{Cell Ah (2C rate)} * 3.6\text{kJ} \quad (23)$$

$$\text{Seg Energy} = (7.5 * 3) * 65 * 3.6 \quad (24)$$

$$\text{Seg Energy} = 5265\text{kJ} \quad (25)$$

$$\text{Seg Energy} = 5.265\text{MJ} \quad (26)$$

## 5.2 Cell Description

*Describe the cell type used and the chemistry and complete the following table.*

The cells used are Automotive Energy E5 lithium ion (pouch type) cells, and they were fabricated into modules by Nissan for their Nissan Leaf electric vehicle. Their datasheets are not included because of our team's NDA with Nissan. We are working to be able to share the necessary information, but the cell values noted are from our testing of the cells and other sources like the US Department of Energy ([Link to source](#) and located in the appendix.) Through their advanced testing, they note the maximum cell voltage at 4.2V and the minimum cell voltage at 2.5V, which aligns with our own research on other cells with lithium-manganese chemistry ([Link to source](#)), which says that they should stay over 3V for battery safety and the safety of the drivers and/or operators.

Cell Manufacturer and Model	Automotive Energy Supply Corporation Model E5
Cell type	Pouch type, Yes
Are these pouch cells	Yes
Cell nominal capacity at 2C (0.5 hour) rate	65.0 Ah
Datasheet nominal capacity	NDA
Maximum Voltage (during charging)	4.1V
Nominal Voltage (data sheet value)	3.75 V
Minimum Voltage (AMS setting)	3V
Maximum Cell Temperature (charging - AMS setting)	50 °C
Maximum Cell Temperature (discharging - AMS setting)	60 °C
Cell Chemistry	Lithium Ion - Laminate type Cathode/Anode Material: LiMn2O4 with LiNiO2/Graphite

Table 19: Main cell specification

*Show your calculations for 2C nominal AH capacity if the data sheet uses a different discharge rate. Refer to FH rules Appendix A*

### 5.3 Cell Configuration

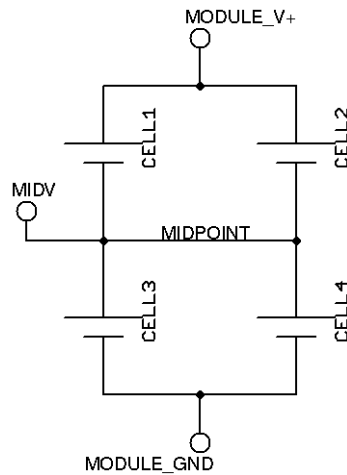

Figure 29: Schematic of one module, which includes 4 cells in a 2s-2p configuration, with shutdown separators in each cell

Describe cell configuration, show schematics, cover additional parts like internal cell fuses etc. Describe configuration: e.g.,  $N$  cells in parallel then  $M$  packs in series, or  $N$  cells in series then  $M$  strings in series. The full accumulator has 12 modules in series. Each module has 2 cells in series in 2 parallel strings, shown in Figure 29. Therefore, the full configuration is 12s(2s2p).

Does the accumulator combine individual cells in parallel without cell fuses?  Yes  No

The modules (which are all in series), each have a string of 2 cells in parallel, as seen in Figure 29. In the middle of each cell there is a shutdown separator, which acts as a fuse in over-current conditions. The terminal marked in white in Figure 30 references the point between the two parallel cell strings. These modules are commercially sold in Nissan Leaf vehicles without issue, so we are referencing their safety to prove ours.

### 5.4 Segment Maintenance Disconnect

Describe segment maintenance disconnect (SMD) device, locations, ratings etc.

Is HVD used as SMD?	No
Number of SMD devices	3
SMD MFR and Model	SMD - Lear Corporation Fuse inside: Bussman EV30-350
SMD Rated Voltage (if applicable)	N/A
SMD Rated Current (if applicable)	N/A
Segment Energy (6 MJ max)	5.265 MJ
Segment Energy Discharge Rate (Ref FH Rules Appendix A)	2C

Table 20: SMD Data

We are not using the fuse inside to act as a fuse (as it has a higher time-current curve than our main fuse) but as busbars due to the shape of the inside of the SMDs. We have our main fuse in series with the SMD fuses. This design was cleared in ticket #1320.



## 5.5 Lithium Ion Pouch Cells

The vehicle accumulator uses individual pouch cells.

Yes  No

*Note that designing an accumulator system utilizing pouch cells is a substantial engineering undertaking which may be avoided by using prismatic or cylindrical cells. If your team has designed your accumulator system using individual Lithium-Ion pouch cells, include drawings, photographs and calculations demonstrating compliance with all sections of rule EV3.9. If your system has been issued a variance to EV3.9 by the Formula Hybrid rules committee, include the required documentation from the cell manufacturer.*

Our team has designed an accumulator using modules that include individual lithium-ion pouch cells. However, these modules are unmodified OEM units, used in the Nissan Leaf. We opened ticket #1084 clarifying our accumulator plans and received permission to include the modules as they are without including a separate method of cell compression.

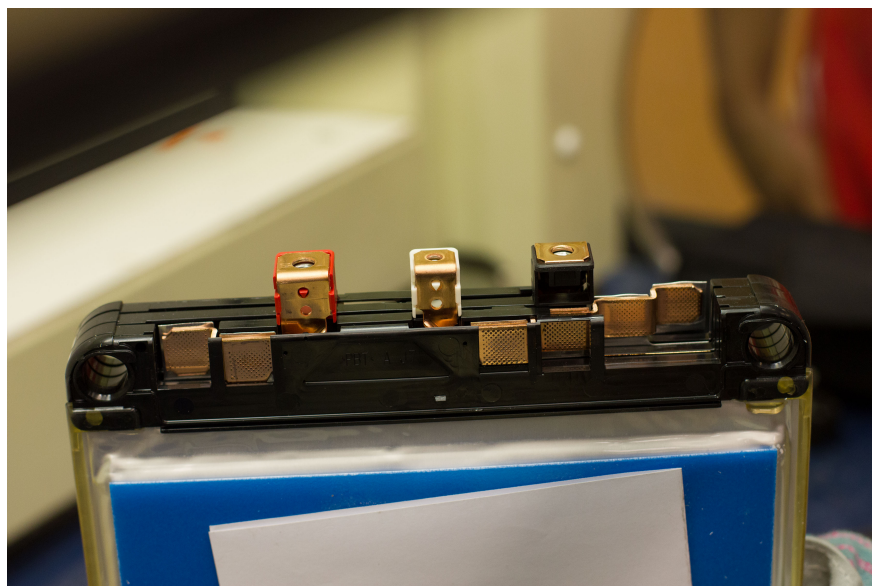

Figure 30: Inside view of a module

## 5.6 Cell Temperature Monitoring

*Describe how the temperature of the cells is monitored, where the temperature sensors are placed, how many cells are monitored, etc. Show a map of the physical layout. Provide schematics for team-built electronics.*

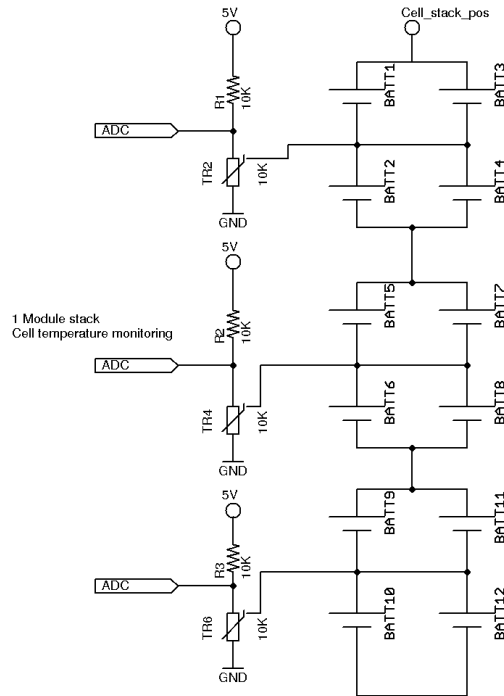

Figure 31: Schematic of the temperature monitoring in one segment (3 modules)



Figure 32: The location of the busbars, as seen on 2/4 segments.

The temperature of the cells is monitored using 10K thermistors attached to the negative terminals. The middle pole of each module is considered the ground of two cells. Each module's temperature is measured at its midpoint (described in figure 29). The thermistors are used to form three voltage dividers. When the temperature of the cells increases, the resistance decreases, resulting in less voltage drop across the thermistor. Four analog to digital converters attached to each of the voltage dividers is then used by the ATmega16M1 used in the CAN system to determine whether the temperature is too high or low. If the temperature is out of range (high or low), the shutdown system activates. There is a pull up resistor that pushes the output voltage to 5V if the ADC is a past a certain threshold and 0V otherwise. Because we are monitoring the negative terminals of half of the cells in each module, we are monitoring 50% of the total cells.

The distance between the bottom of the PCB and the top of the busbar is 3.2 mm (0.126 in.), while the distance from thermistor to terminal is 0.32 in. Because the cells are arranged within the module by the manufacturer, the distance from the busbar to the actual cell terminals (instead of the module terminals) is unknown.

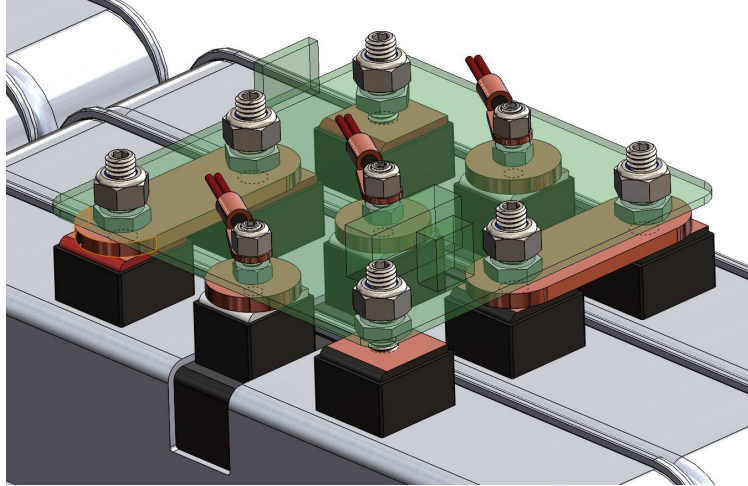

Figure 33: Side view of the busbar-thermistor stackup, with aluminum nuts between the thermistors (the ring terminals shown) and the copper busbars.

Number of Cells with Temperature Monitoring	24
Total Number of Cells	48
Percentage Monitored	50%
Percentage Required by FH Rules	30%
If sensor monitors multiple cells, state how many	2: see Fig. 31

Table 21: Cell Temperature Monitoring

## 5.7 Accumulator Isolation Relays

Describe the number of AIRs used and their locations. Also complete the following table.

The AIRs used are EV Kilovac 200 SPST relays from Tyco Electronics. The relays require the use of an economizer, which switches their current after 150 ms so they do not draw as much current. The positive pole AIR and negative pole AIR are located in the accumulator, separated from the cells by two sheets of 1/32" FR4/G10, sandwiching a 0.035" thick 403 stainless steel panel.

The circuitry to support the AIRs- including precharge and discharge circuitry, AMS relays and interlocks can be seen in 36. Its PCB is seen in figure 35

MFR & Model	Tyco Electronics, Kilovac EV200
Contact arrangement	1 form x (SPST-NO-DM)
Continuous DC current rating	500A
Overload DC current rating	2000 A for 1 cycle, at 32 VDC
Max operation voltage	900VDC
Nominal coil voltage	9 -36 VDC
Normal Load switching	See figure 34

Table 22: AIR data

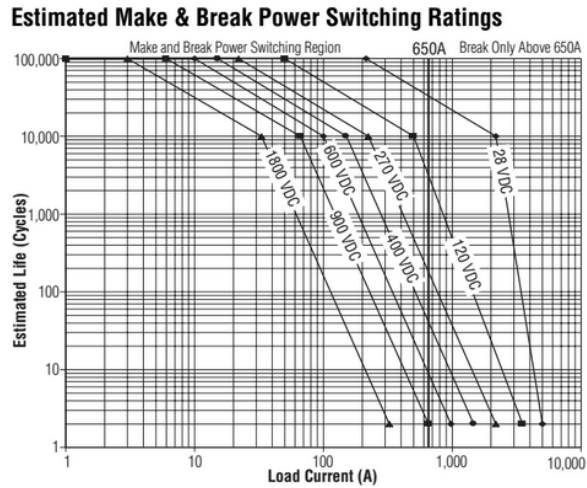

Figure 34: Switching specification for the AIR relay datasheet

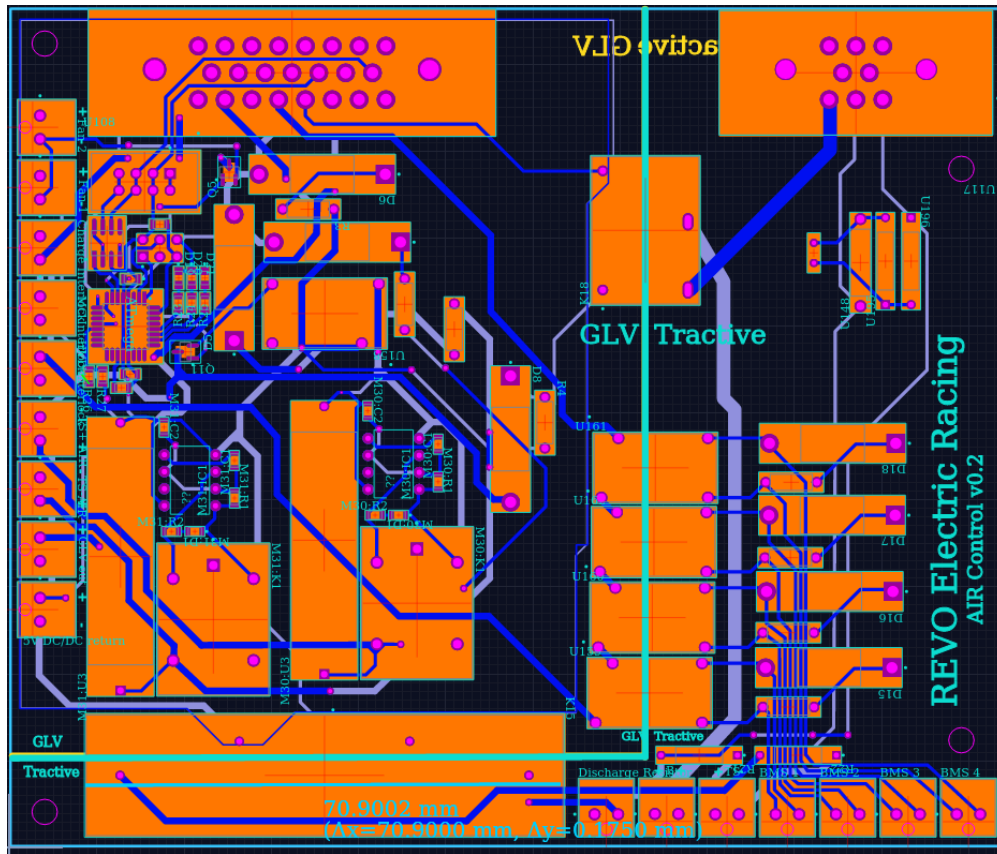

Figure 35: PCB CAD of the AIR control board. The cyan line dictates the separation between GLV and TS voltages.

### 5.8 Accumulator Management System

Describe the AMS and how it was chosen. Describe generally how it meets the requirements of EV3.7



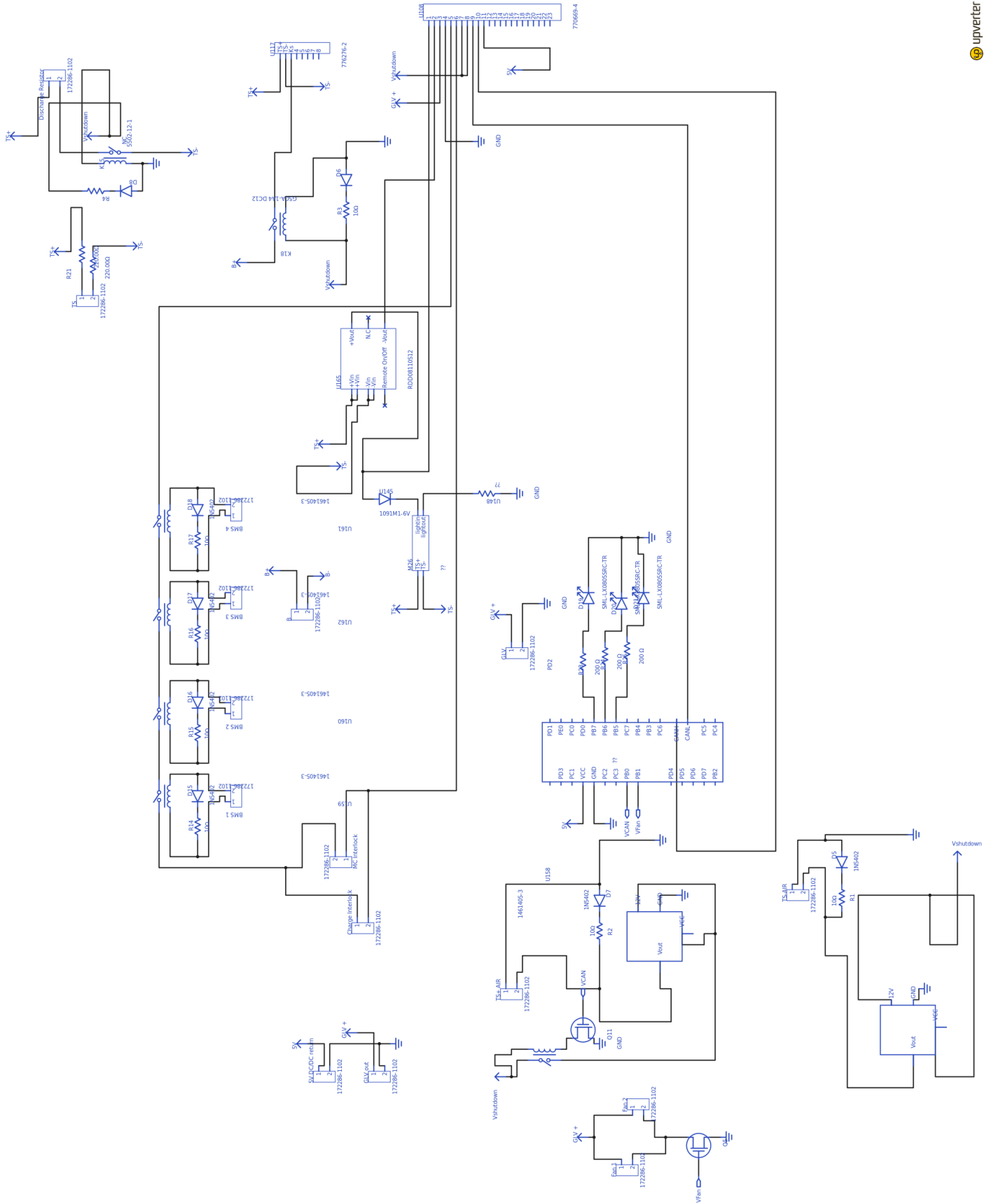

Figure 36: AIR control board schematic, not including the economizers

AMS MFR and Model	Team-made
Number of AMSs	4
Upper cell voltage trip	4.1V
Lower cell voltage trip	3V
Temperature trip	58 °C

Table 23: AMS Data

- Describe other relevant AMS operation parameters.
- Describe how many cells are monitored by each AMS board, the configuration of the cells, the configuration of the boards and how AMS communications wiring is protected and isolated.
- Describe how the AMS opens the AIRs if an error is detected
- Indicate in the AMS system the location of the isolation between TS and GLV

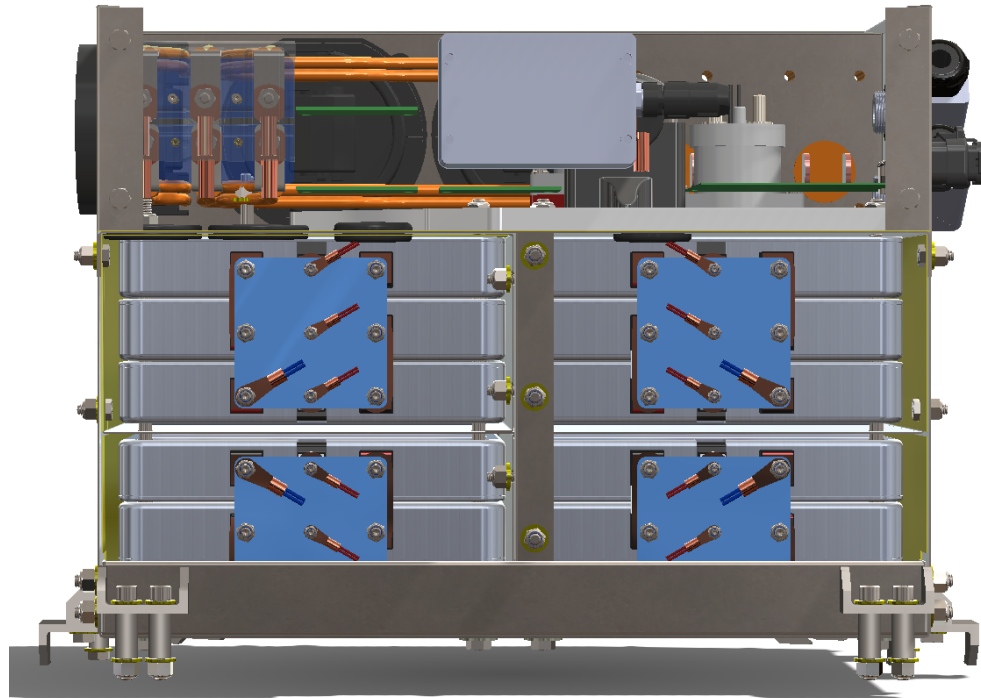

Figure 37: Accumulator, Front View

The AMS monitors 6 groups of cells in series. Each module contains 4 cells, 2 series x 2 parallel, so each AMS monitors 3 modules, or 12 cells (6 series x 2 parallel). There are 4 AMS boards. Each AMS board is coupled to a cell breakout board, which includes 4 thermistors and bolts to the power terminals of three modules, as shown in Figure 37 (blue circuit boards) and described in section 5.6. The purpose of the cell breakout boards is to help manage wiring inside the accumulator. The cell breakout boards will have compression limiting copper pads at the terminal bolts and will be spaced above the bus bars using copper washers. The cell top schematics and PCB CAD are shown in figures 40, 41, 42.

The AMS shunts 3 A when the cell gets above 4.1 V and opens a relay in line with the shutdown circuit if any cell drops below 3 V or above 4.1V. The AMS opens a relay in line with the shutdown circuit if any cell

gets above 58 °C. Please see figure 56 for a schematic of the shutdown circuit's relays.

Figure 38 shows the voltage that will be read by the BMS at different temperature readings. The BMS has an ADC with 10 bit resolution meaning that voltage differences of less than 0.005V can be detected. As seen in Figure 39 the worst case scenario for over-temperature sensing is when the temperature is at 62 °C. For this reason we will choose to be safe and raise an error when the temperature is at 58 °C which has a worse case reading of 60 °C.

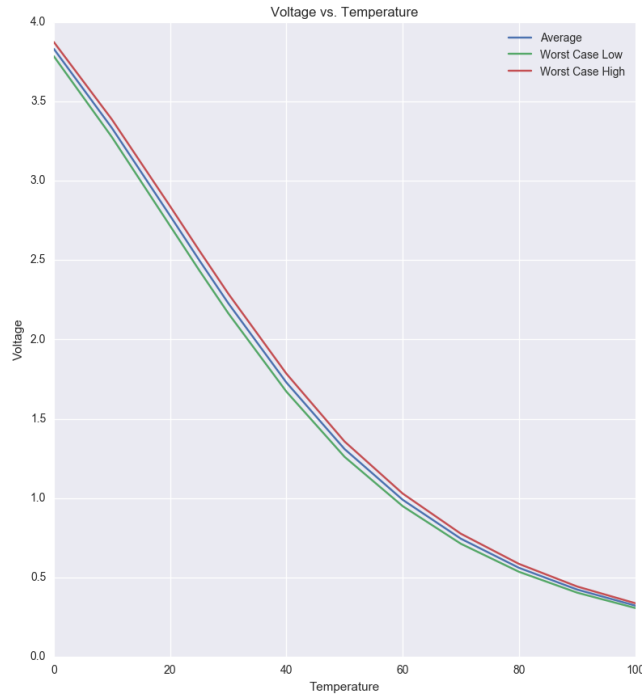

Figure 38: Voltage measured at BMS vs. temperature the cell is at.

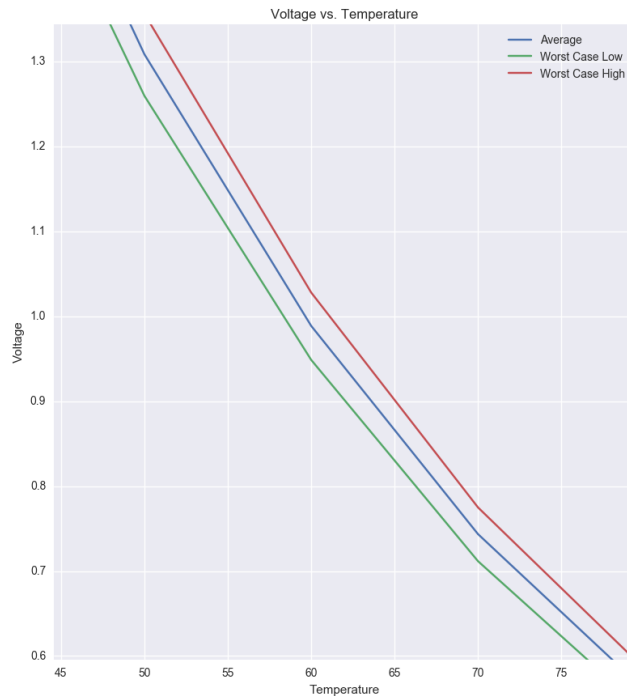

Figure 39: Voltage measured at BMS vs. temperature the cell is at. This just shows the voltage difference at different temperatures around 60 °C

CAN communication from the board is isolated via a TI ISO1050DUBR (isolated CAN transceiver). Only CAN communication is used to have the information from each AMS relayed to the rest of the system, and the boards are otherwise independent of each other. On each cell-top board, there are 7 surface mount Bel C1Q 3 A fuses for the seven voltage inputs (Lowest voltage reference, and top voltage of each of 6 cells.) The relays which allow the AMS to control the shutdown circuit provide isolation between the AMS and the GLV system, as well as the isolated CAN transceivers. Please see Figure 43 on the following page for the schematic of one of the battery management system boards, and the circuitry it has to measure the relative voltage, shunt, and input the data of voltage and temperature to a ATmega16M1 chip (which communicates to the CAN system). Note that the AMS relays are located on neither the cell top board or the AMS boards, but is included in the AIR control board, which controls the power to the AIRs and the precharge/discharge circuitry. The AIR control board is shown in figure 35, for the pcb spacings. Its schematic is found in figure 36.

The AMS shunts 3 A when the cell gets above the maximum cell voltage. Each AMS opens its relay in line with the shutdown circuit if any cell in its segment drops below the minimum cell voltage. The AMS opens a relay in line with the shutdown circuit if any cell in its segment gets above 58 °C. Please see figure 56 for a schematic of the shutdown circuit's relays.



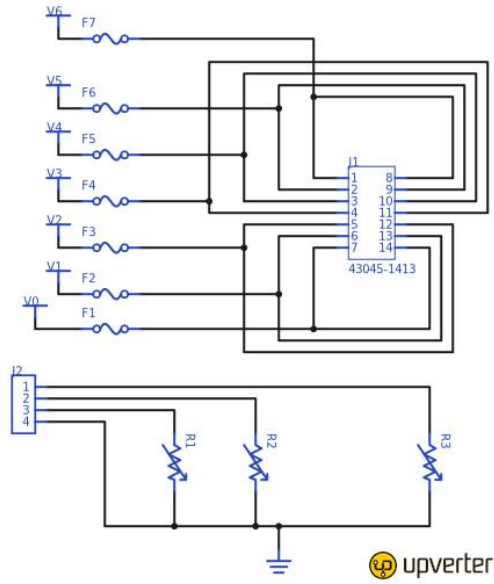

Figure 40: Schematic of the cell-top board

There are two versions of the PCB for the cell top board, as the cells are mirrored. The PCBs have the same content, but are mirrored.

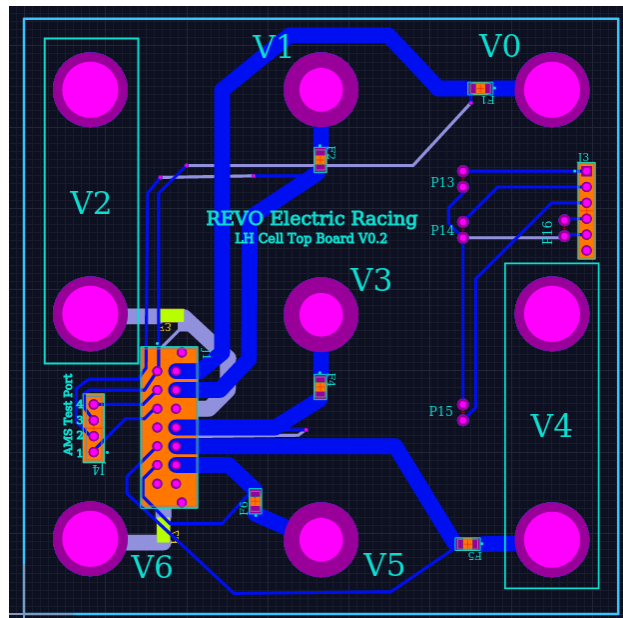

Figure 41: The left-side version of the cell top board that connects battery information to the AMS.

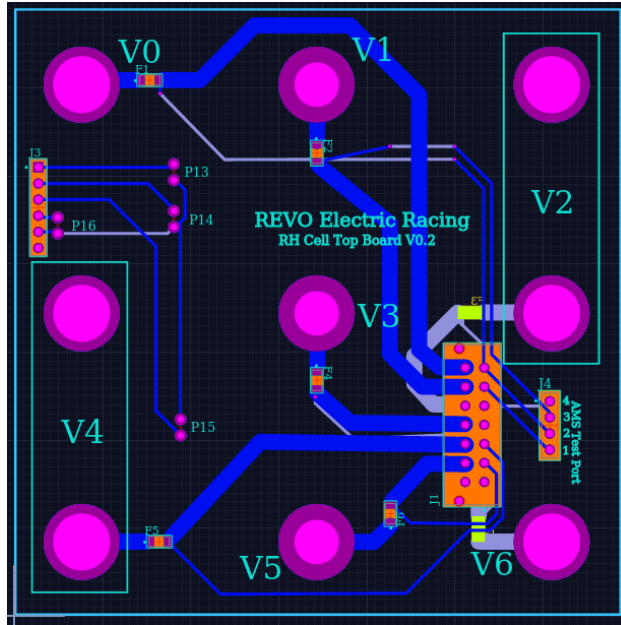

Figure 42: The right-side version of the cell top board that connects battery information to the AMS.

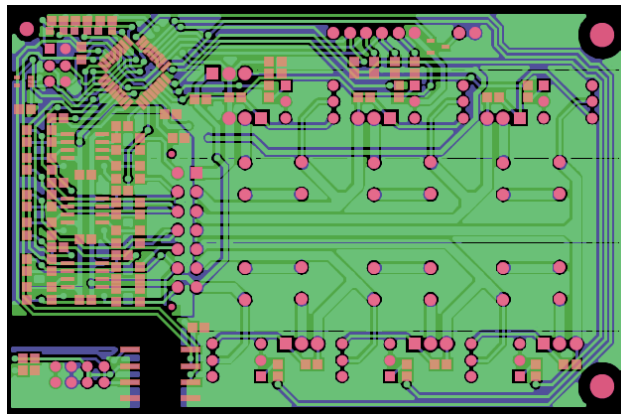

Figure 44: Accumulator Management System PCB

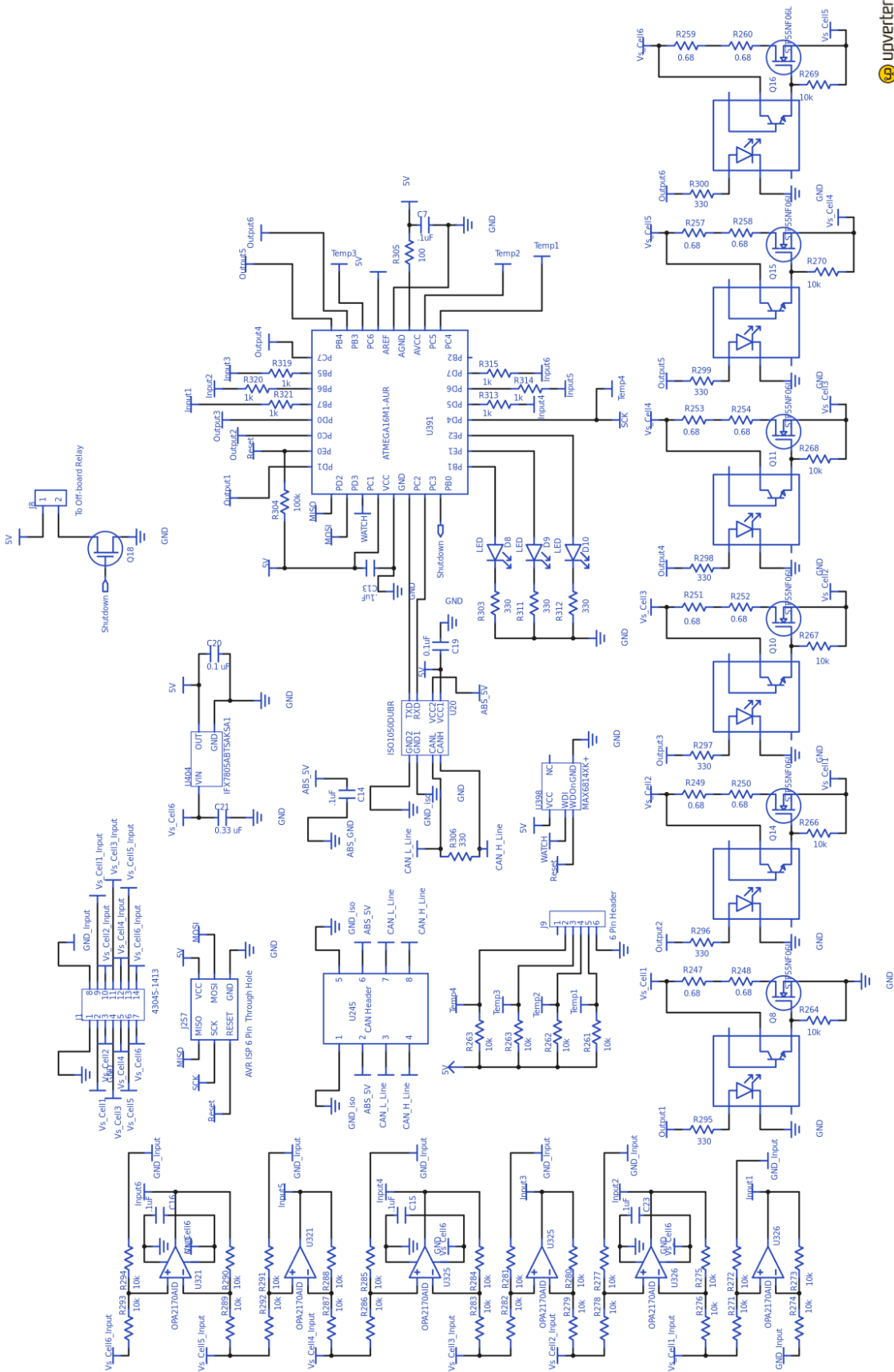

Figure 43: Accumulator Management System schematic

## 5.9 Accumulator Wiring, Cables, Current Calculations

*Describe internal wiring with schematics if appropriate. Provide calculations for currents and voltages and show data regarding the cables and connectors used. Discuss maximum expected current, DC and AC, and duration. Compare the maximum values to nominal currents.*

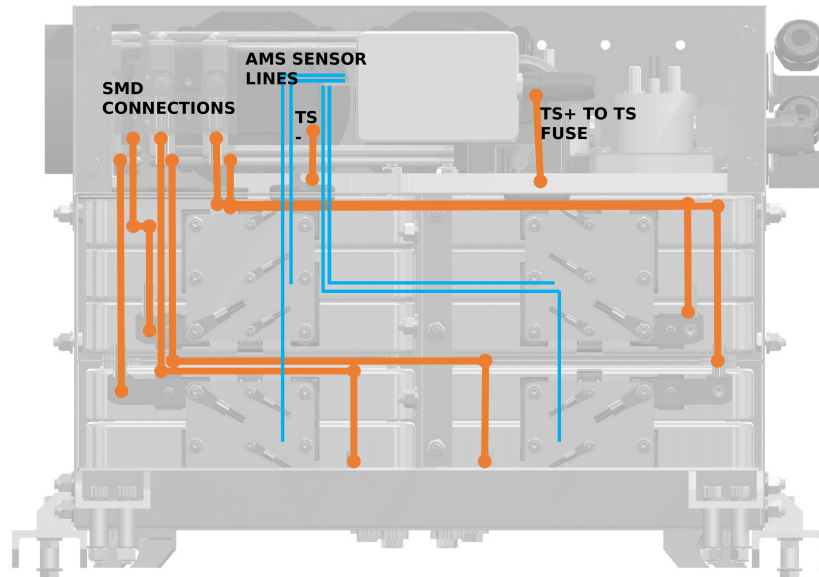

Figure 45: Side view of accumulator wiring: All wiring passes through grommets holes to the top of the pack. Modules within segments are connected using copper bus bars. Cell top boards allow connection of the AMS to individual modules.

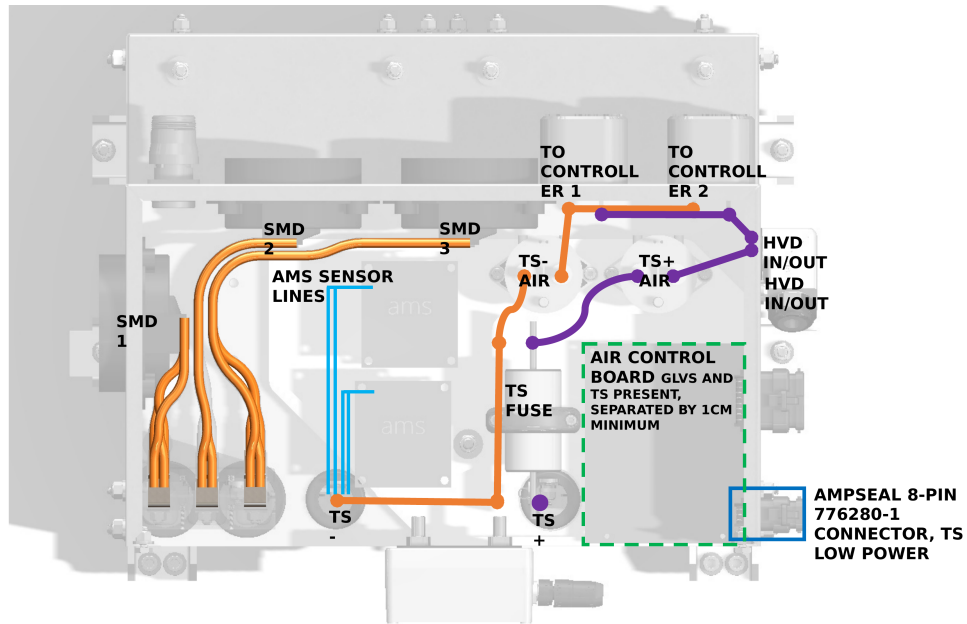

Figure 46: Top view of accumulator wiring: TS wiring is routed through 3 SMDs in order to segment the accumulator. The pack is fused before the Ts+ AIR then connected to the HVD. The high voltage line is split within the accumulator for the two independent motor controllers. The AMS is located in the center of the pack and monitors cell health during driving and charging. The AIR Control Board links the shutdown circuit to the AIRs and is externally connected with AMPSEAL connectors.

Wire type	Dual Insulated 2 AWG
Current rating	181 A
Maximum operating voltage	600 V
Temperature rating	150 °C

Table 24: Wire data of the company: Delphi, 35 mm<sup>2</sup>

The maximum expected current when at 10C is 660A. The nominal current is under NDA. We do not expect this max current draw to be an issue due to our current limiting fuses, and that the motors are wired completely in parallel, thus taking half the load.

The high current (motor, motor controller) wires used for the tractive system will be as described in table 24. The low current (IMD, Lights DC-DC, GLV DC-DC and ready to drive sound) TS connections will be made with the wire described in tables 25 - 29.

Wire type	CnC Tech, 22 AWG
Current rating	7A
Cross sectional area	0.326 mm <sup>2</sup>
Maximum voltage	600V
Temperature rating	120 °C
Wire connects the components	In the TS V low current path

Table 25: Wire data of the company: CnC Tech, 0.326 mm<sup>2</sup>

Wire type	NTE Electronics, 22 AWG
Current rating	7A
Cross sectional area	0.0005064 in <sup>2</sup>
Maximum voltage	300V
Temperature rating	90 °C
Wire connects the components	In the TS V low current path

Table 26: Wire data of the company: NTE Electronics 0.0005064 in<sup>2</sup>

Wire type	CnC Tech, 22 AWG, AWM style 11047
Current rating	7A
Cross sectional area	0.0005064 in <sup>2</sup>
Maximum voltage	600V
Temperature rating	105°C
Wire connects the components	In the TS V low current path

Table 27: Wire data of the company: CnC Tech 0.0005064 in<sup>2</sup>

Wire type	AWC Allied Wire, 22 AWG, AWM style 1569
Current rating	7A
Cross sectional area	0.0005064 in <sup>2</sup>
Maximum voltage	600V
Temperature rating	105°C
Wire connects the components	In the TS V low current path

Table 28: Wire data of the company: AWC Allied Wire, 0.0005064 in<sup>2</sup>

Wire type	HosaTech Speaker Wire, 12 AWG, OFC
Current rating	40A
Cross sectional area	0.005125 in <sup>2</sup>
Maximum voltage	125V
Temperature rating	105°C
Wire connects the components	The HV Charging power to the accumulator

Table 29: Wire data of the company: Hosa Tech, 0.005125 in<sup>2</sup>

## 5.10 Accumulator Indicator

*If accumulator container is removable, describe the indicator, including indicating voltage range*

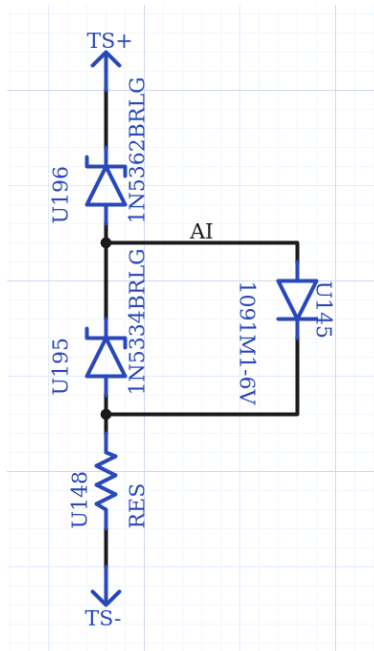

Figure 47: Schematic of the accumulator indicator

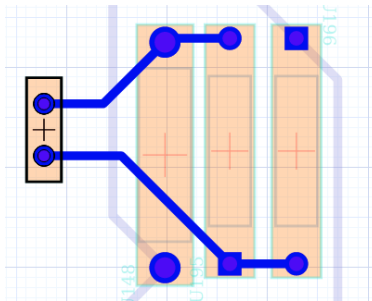

Figure 48: Zoom in on the section of the PCB containing the accumulator indicator (the AIR control board)

The accumulator will be removable and removed each time for the charging process. The accumulator indicator is a small light within the accumulator that can be seen from the outside. The light will turn on at 30VDC because the top zener diode has a breakdown of 28V. From 30-100V, the light will be shining. The light, which is located on the AIR control board, will be placed near the window of the accumulator for visibility. It is fused behind the same 1A fuse protecting the TS low current lines as the TSMPs, GLV DC-DC converter and TSEL/TSVPs.

## 5.11 Charging

*Describe how the accumulator will be charged. How will the charger be connected? How is the accumulator to be supervised during charging?*

The accumulator will be charged using a Delta Q Technologies QioQ 1000 Series charger (UL listed). This charger has a custom charging process for the accumulator. The charging process is a constant current at 17.0A until the battery voltage reaches 4.15Vpc, and then constant voltage at 4.15Vpc until the current tapers to 2.0A. When charging, the accumulator will be located on a hand cart, with a charging interlock, AMS, emergency stop button, and IMD. These components will make up a small version of the shutdown system in order to protect the accumulator, and the connections for this circuitry can be found on the charging PCB and the AIR control board. The charger will connect to the charging connector (Deutsch

6-pin, P/N: HD10-6-12P, HD16-6-12S) to the accumulator, and will go through the TS side of the AIRs, connecting to the TS, while the interlock is located in the connector's two smaller pins. Therefore, the AMS's, IMD and E-stop will all be able to open the AIRs in the case of an emergency. The shutdown components and PCB will be mounted to the charging cart, and a grounding point will be put to earth ground with green 16 AWG wire. Also, a person with knowledge of the charging process will stay with the accumulator at all times.



Figure 49: Visual of the charger from the Delta Q Technologies QioQ 1000 Series

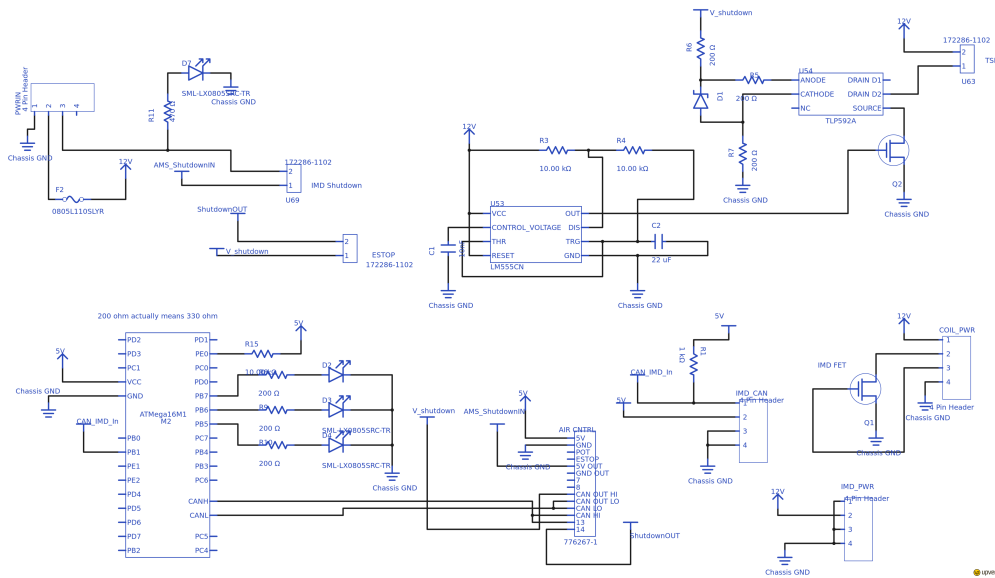

Figure 50: Schematic of the charging shutdown system, not including the AMS and its relays (located on the AIR control board). The connections to the Air control board are made through the 14-pin connector



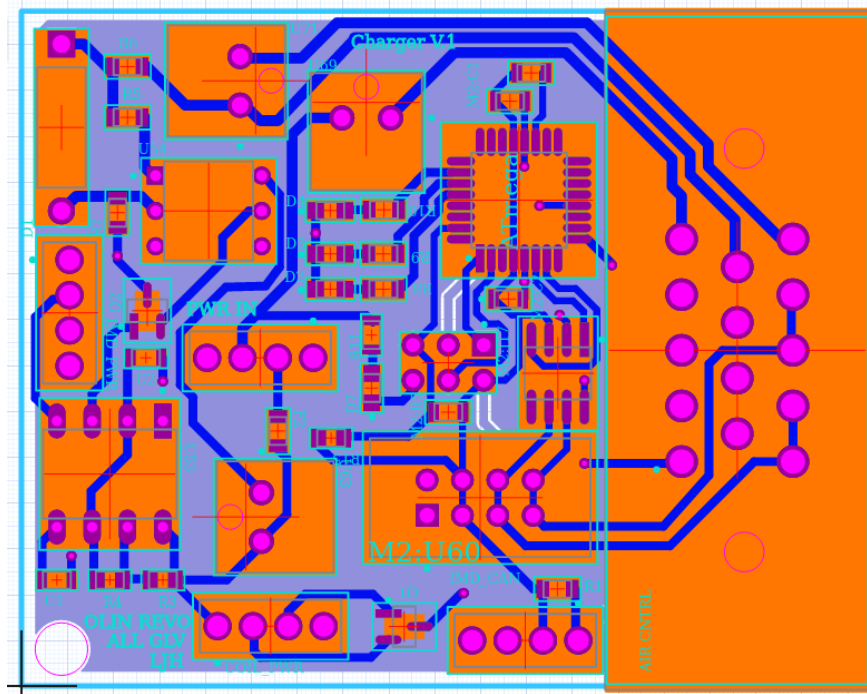

Figure 51: CAD of the charging shutdown PCB. All connections on the PCB will be low voltage.

Charger Manufacturer and Model	Delta Q Technologies QioQ 1000 Series
Maximum charging power	70.55 W
Isolation	Yes
UL Certification	Yes
Do you have a waiver from the FH rules committee?	N/A
Maximum charging voltage	4.15 V
Maximum charging current	17.0 A
Interface with accumulator	Connector with interlock
Input voltage	125VAC or 250VAC
Input current	13A@125VAC or 10A@250VAC

Table 30: Charger data



Figure 52: Cart with a deadman's lock for carrying the accumulator

## 5.12 Accumulator Container/Housing

*Describe the design of the accumulator container. Include the housing material specifications and construction methods. Include data sheets for insulating materials. Include information documenting compliance with UL94-V0, FAR25 or equivalent. If the housing is made of conductive material, include information on how the poles of the accumulators are insulated and/or separated from the housing, and describe where and how the container is grounded to the chassis. Include additional photographs if required to comply with rule EV3.2. Show how the cells are mounted, use CAD-Renderings, and include calculations showing compliance with FH Rules EV3.4.*

The accumulator is comprised of flanged 403 stainless steel sheet metal panels, meeting the material and fastener requirements set by Formula SAE Electric rule EV 3.4.6. This rule specifies that the minimum sheet thickness for the floor is 0.049" steel and 0.035" steel for vertical and internal walls. The panels are fastened together using a minimum of three 1/4" SAE Grade 5 at any joint, except at the intersection of internal walls. These intersections will be spot welded with weld area equivalent to a linear weld along the same length of joint. We will also be conducting a pull-test of test parts to ensure our spot welding settings are correct for full penetration. We have received a rules clarification # 4795 stating that spot welding is regulation-compliant. The Nissan modules are additionally isolated by an additional layer of G10/FR4 Garolite, a fiberglass-cloth with a flame-retardant resin. G10/FR4 meets MIL-I-24768/27 and UL94-V0 for flame retardance (McMaster-Carr P/N 8667K55). These barriers do not create electrical insulation, which is performed internal to each module. We have insulation ratings between the Nissan module case and the cell terminals, but this information is under NDA.

In this design the Nissan/AESC battery modules are laid flat relative to the car, and broken up into segments containing less than 6MJ of total stored energy. The accumulator has two covers, both lined with FR4 insulating material. The cover revealing the battery modules also serves as a structural vertical wall, and great care was taken in the design to ensure compliance with EV 3.4.6.

The accumulator is mounted to the chassis using 10 SAE Grade 5 5/16" bolts through welded, gusseted tabs.

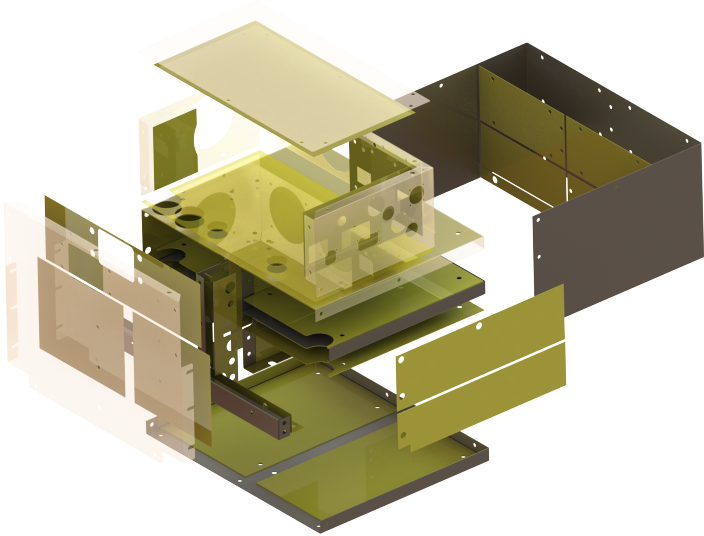

Figure 53: Accumulator Frame Exploded View

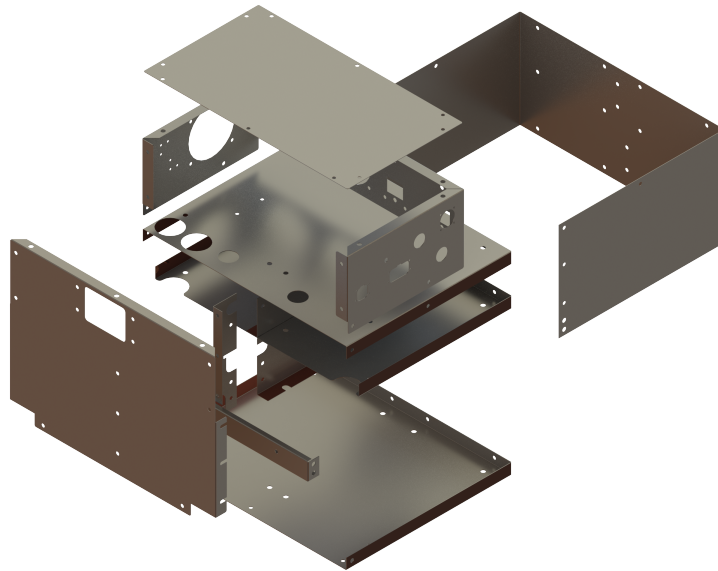

Figure 54: Sheet metal construction of the accumulator, isometric

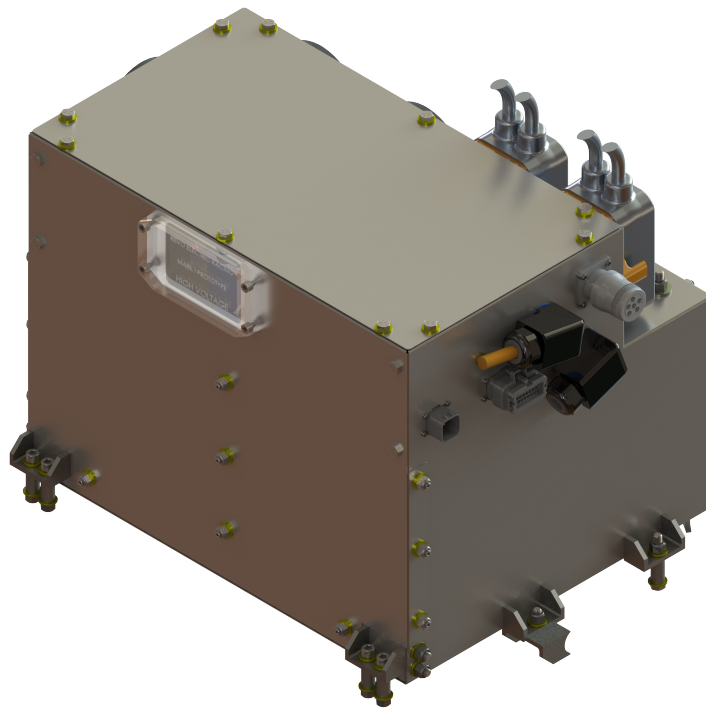

Figure 55: Overall view of the accumulator container, with the lid on.

## 6 Safety Controls and Indicators

Person primarily responsible for this section:

Name:	Lisa Hachmann
e-mail:	<u>Lisa.Hachmann@students.olin.edu</u>

### 6.1 Shutdown circuit

*Include a schematic of the shutdown circuit for your vehicle including all major components in the loop*

Please see figure 56 for the shutdown schematic, on the next page.

*Describe the method of operation of your shutdown circuit, including the master switches, shut down buttons, brake over-travel switch, etc. Also complete the following table*

The shutdown circuit is a circuit, carrying the power of the AIR all in series. The shutdown circuit utilizes a broad range of sensors for vehicle and driver safety.

The brake over travel switch is a single pole switch that is located behind the brake, and in the event it over-travels, it will open the shutdown circuit.

The master switches are single pole switches that must be manually closed in order to close the shutdown system. The keys for the master switches are kept in the active Rules and Safety Officer's possession at all times. When disconnected from the vehicle, the keys are also connected to each other, thus disabling closing both switches simultaneously due to the physical separation of the switches and ensuring safety even if the RSO loses possession of the keys. This ensures that a driver can only operate the vehicle under the supervision of the RSO. The RSO will check that the vehicle is clear and safe to start at the voltage level being requested.

The shutdown buttons are emergency stop buttons that are normally closed and single pole. In the event of the emergency, the three buttons (located in the cockpit, right back and left back of the vehicle) can be pushed and then open the shutdown circuit.

The AMS also has relays that carry the power in the shutdown circuit. They are powered by CAN nodes, and are normally open single pole relays. The switch closes the shutdown circuit unless there is a anomaly in the cell voltage or temperature.

The IMD constantly checks for ground faults, and has a high output when there is no ground fault. With a high ground fault, if the IMD reset button is pressed, the IMD relay can latch and close the shutdown circuit.

Also involved in the shutdown system is a brake over travel switch. This circuitry is built to the FSAE Electric competition rules, and aims to check if there is current flowing from the motor controller while the brake is being pressed (hard). The circuitry cannot include software, so a 555 timer and hall effect sensors are used.

The economizer circuitry for the AIRs (in parallel), carry the shutdown circuit and control the AIRs current draw. The economizer is required circuitry by the AIRs used, and lower the continuous current draw through switching.

A switch for GLV power is given to the driver for the ability to see the error messages from CAN. The master switch for the GLV will still need to be closed in order for the driver to be able to gain GLV power.

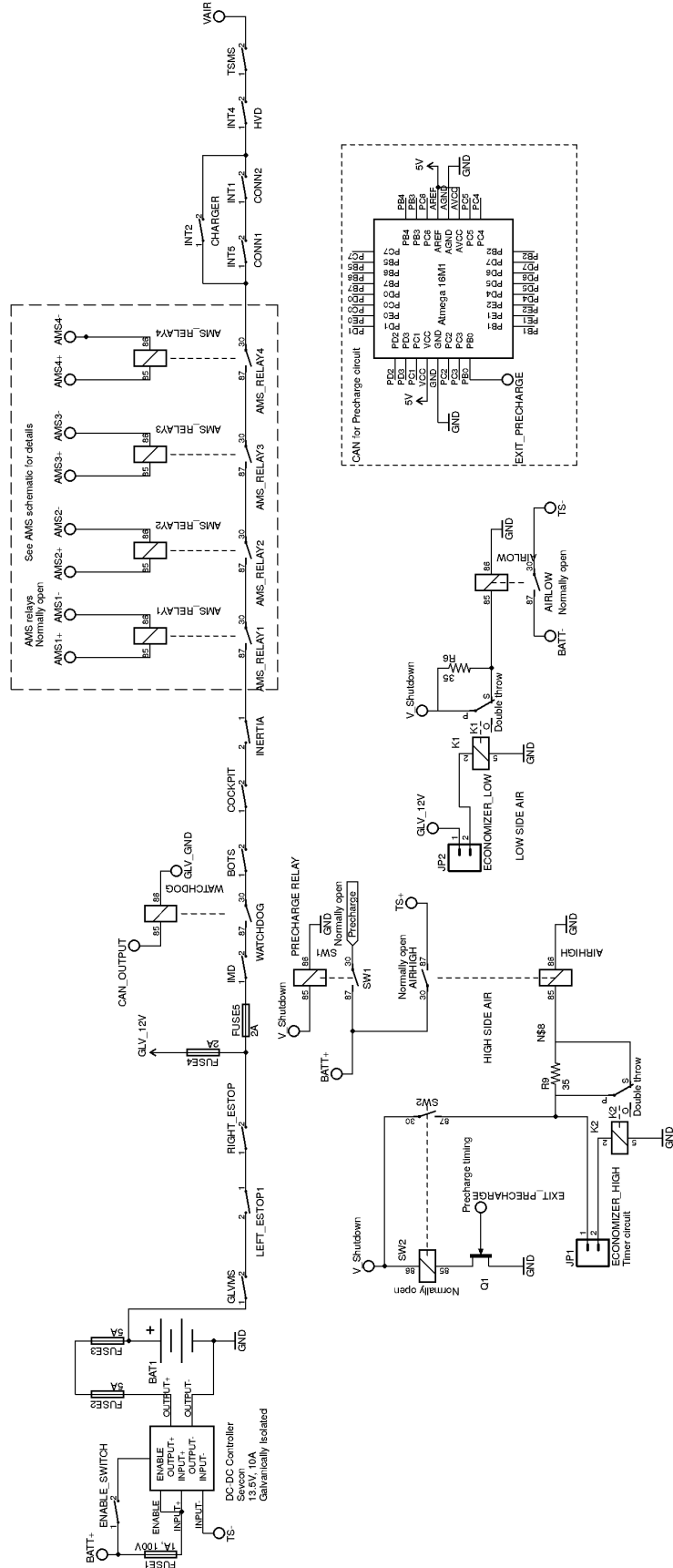

Part	Function (Momentary, Normally Open or Normally Closed)
Main Switch (for control and tractive-system; CSMS, TSMS)	Normally Open (x2)
Brake over-travel switch (BOTS)	Push-Pull
Shutdown Buttons (BRB)	Normally Closed (x3)
Insulation Monitoring Device (IMD)	Normally Open
Battery Management System (AMS)	Normally Open (x4)
Interlocks (if used)	Normally Open

Table 31: Switches and devices in the shutdown circuit

*Describe wiring and additional circuitry controlling AIRs. Write a functional description of operation*

The power to the AIRs is all in series until the economizers for each AIR and the AIRs are in parallel. All wiring is 20 AWG and the GLV system is has four fuses in general. There is a 5A fuse on the output of the DC/DC converter and a 5A fuse on the output of the GLV battery. After the e-stops, the GLV 12V splits to be in parallel with the shutdown system, and both the GLV 12V and shutdown system are fused to 2A. For each board that accepts 5V as input for the CAN system, there is a 0.5A PTC resettable fuse on the 5V line (all nodes are in parallel). The shutdown system communicates with the CAN system to ensure simple debugging and software control where permitted.

Total Number of AIRS	2
Coil holding current per AIR	3.8A until 150 ms passed, then 0.4 A
Current drawn by other components wired in parallel with the AIRs	1.5-2A

Table 32: Shutdown circuit current draw

*Provide CAD-renderings showing the shutdown circuit parts. Mark the parts in the renderings*

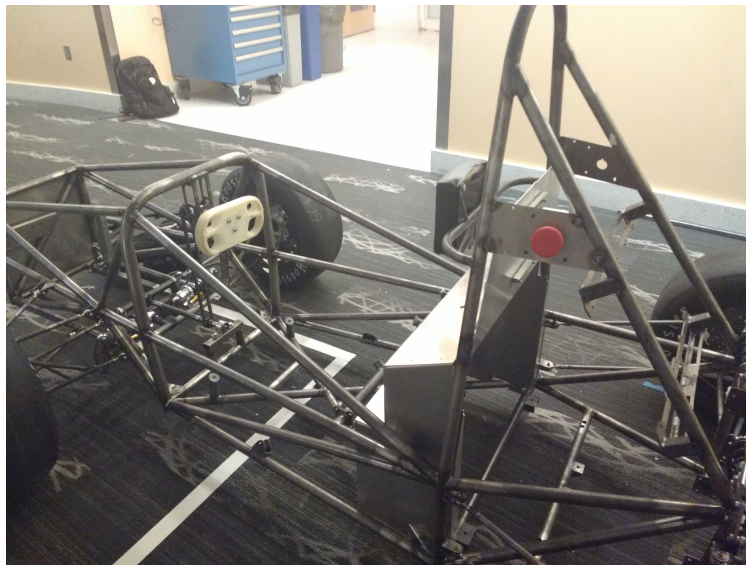
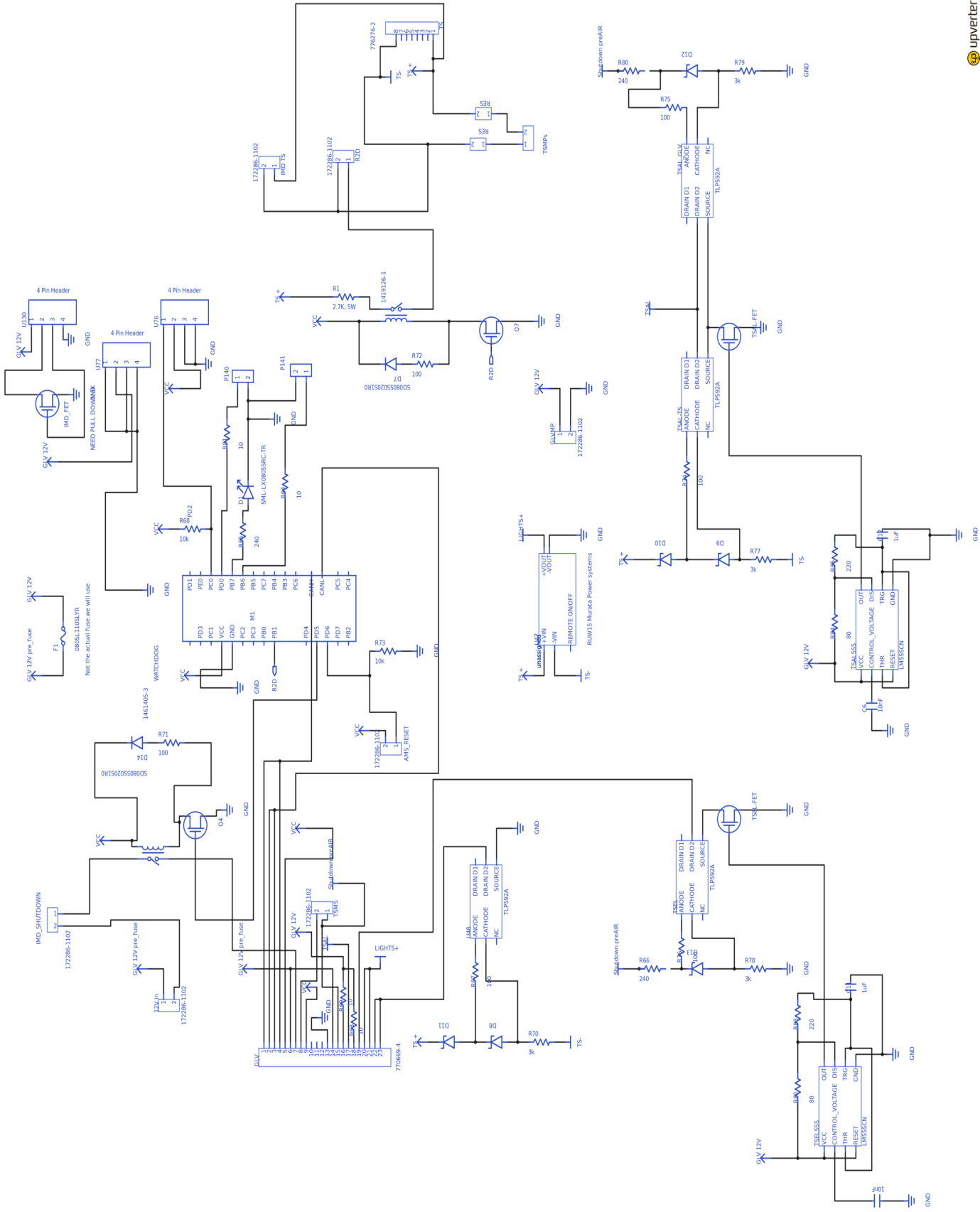

Figure 58: Side Mounted Shutdown Buttons mounted on cars: Easily visible and accessible for E-Stop rescue scenarios





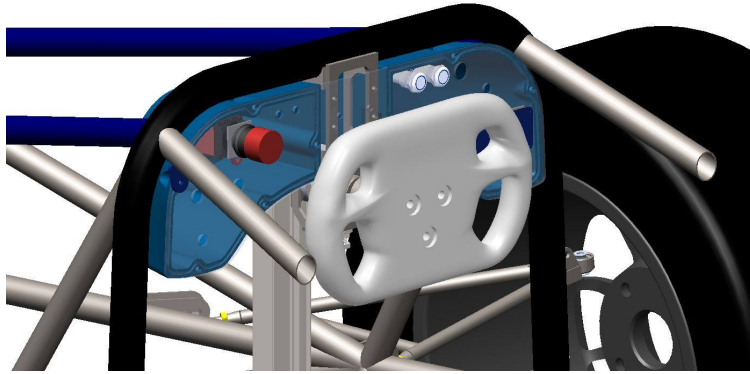

Figure 59: Cockpit Shutdown Button: E-Stop button for driver controlled shutdown

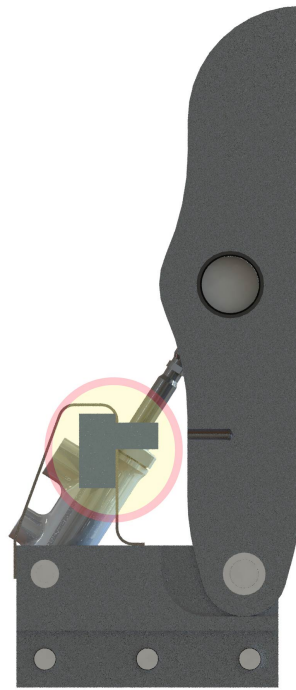

Figure 60: Brake Over-travel Switch: The BOTS is mounted to a sheet metal container which is mounted to the pedal assembly. An aluminum nut threaded over the BOTS acts as the positive stop for the pedal, transmitting the pedal load into the sheet metal rather than the switch itself.

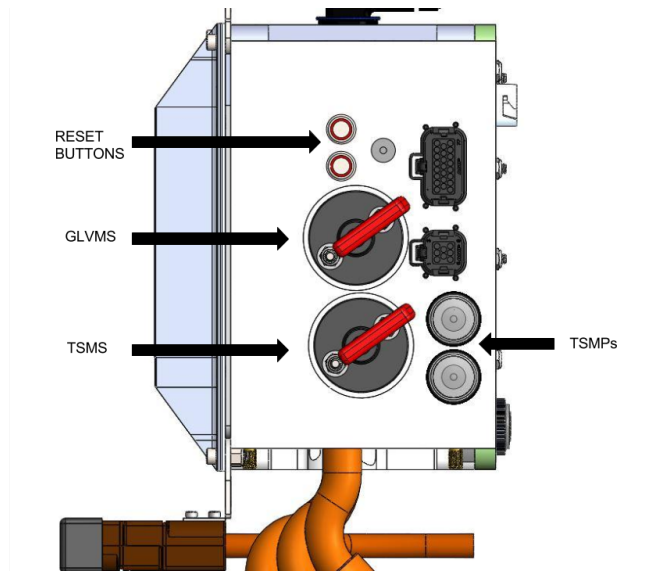

Figure 61: Motor Controller Housing Outside View Diagram- this contains the side panel PCB, MCC PCB and motor controllers inside (both Tractive and GLV components).

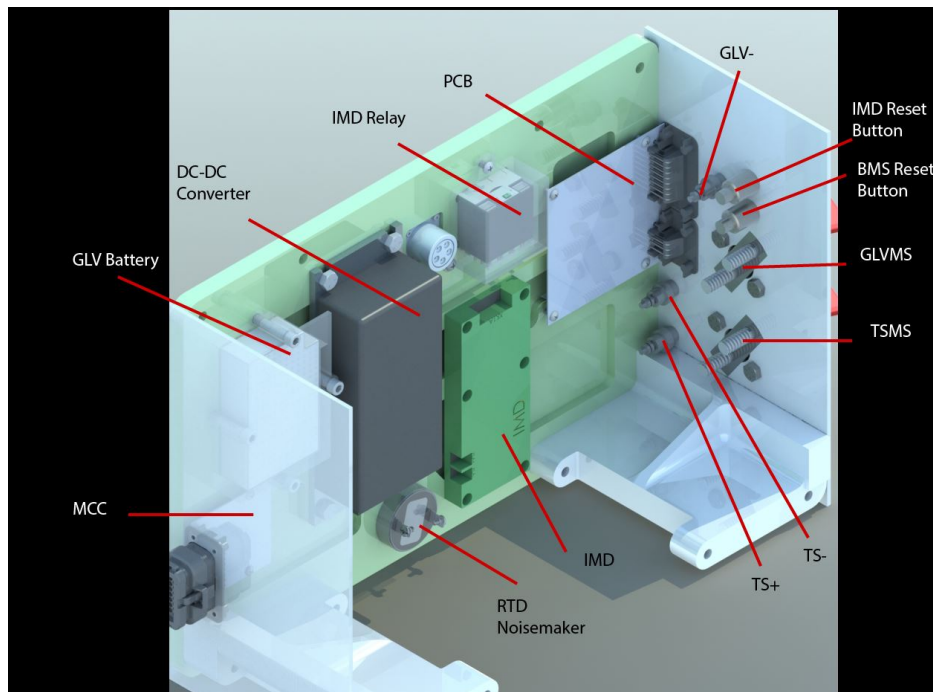

Figure 62: Motor Controller Housing Inside View Diagram

The physical location of the AMS is pictured and discussed in Figure 45.

## 6.2 IMD

Describe the IMD used and use a table for the common operation parameters, like supply voltage, temperature, etc. Describe how the IMD indicator light is wired. Complete the following table. Describe IMD wiring with schematics.

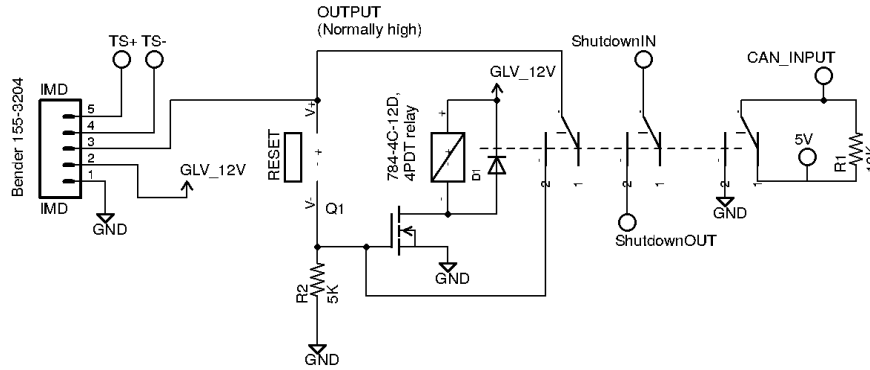

Figure 63: Schematic of the IMD

The IMD will have a high output as long as there is no ground fault detected. The high output will not power the relay until the reset button is pressed in the very beginning start up procedure. Pressing the IMD reset button will "latch" it into its state (by using the first switch). The relay's coil pulls all 4 of the double pole switches to their active states, therefore closing the shutdown circuit and pulling the ATmega16M1 input as low. The input to the microprocessor has a pull-up resistor in case of a disconnection in the wiring. The ATmega16M1 in the motor controller housing (where the IMD is) will notify the ATmega16M1 in the dashboard (where the IMD light is) to turn the pin that the IMD light is on high. The fourth pole is left open. The high voltage power lines that the IMD references are behind the same 1A fuse as used for the TSMPs, TSVP/TSELS, and GLV DC-DC converter.

MFR/Model	Bender ISOMETER IR155-3204
Set Response Value	100 kΩ

Table 33: Parameters of the IMD

Referred from section 6.3 (Reset/Latching for IMD and AMS)

### 6.3 Reset / Latching for IMD and AMS

*Describe the functioning and circuitry of the latching/reset system for a tripped IMD or AMS. Describe wiring, provide schematics.*

If the AMS detects a fault. It opens the shutdown circuit, and latches into that state. When the AMS reset switch, located in the motor controller housing, is pressed, the nearby CAN node passes a message through CAN to the AMS boards. If the accumulator is within safe electrical and temperature operating limits the AMS closes the shutdown circuit.

To reset the IMD an operator other than the driver must push the IMD reset button located on the outside of the car on the side panel, next to the TSMPs, master switches and E-stops. If the output of the IMD is high because there is no ground fault, the reset button will activate the coil and close the shutdown circuit. Please see figure 63 for the latching of the IMD circuit. The push button labelled "RESET" is the form of latching for the IMD- pressing the reset button will energize the relay's coil and allow it to self-energize for the remainder of the time that its output is high (true). The IMD reset button must be pressed in order for the shutdown circuit to be closed (assuming the IMD does not find a ground fault).

### 6.4 Shutdown System Interlocks

*(If used) describe the functioning and circuitry of the Shutdown System Interlocks. Describe wiring, provide schematics.*

The shutdown system does employ interlocks on the main battery connectors and the HVD. The charger's interlock will replace the two main connectors' (to the motor controllers) interlock when the accumulator is charging. All of the interlocks will be fit in their respective high voltage connectors, and be in series with the

shutdown circuit, besides the charger interlock being in parallel with the two main connections (referenced as CONN in figure 64).

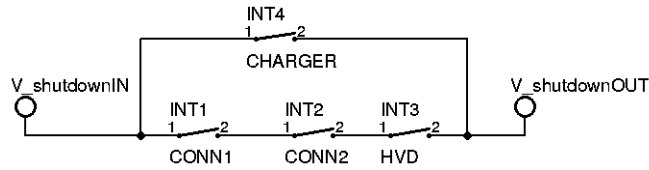

Figure 64: Schematic of the interlocks as a part of the shutdown circuit

## 6.5 Tractive System Energized Light (TSEL)

Describe the tractive system energized light components and method of operation. Describe location and wiring, provide schematics. See EV4.10

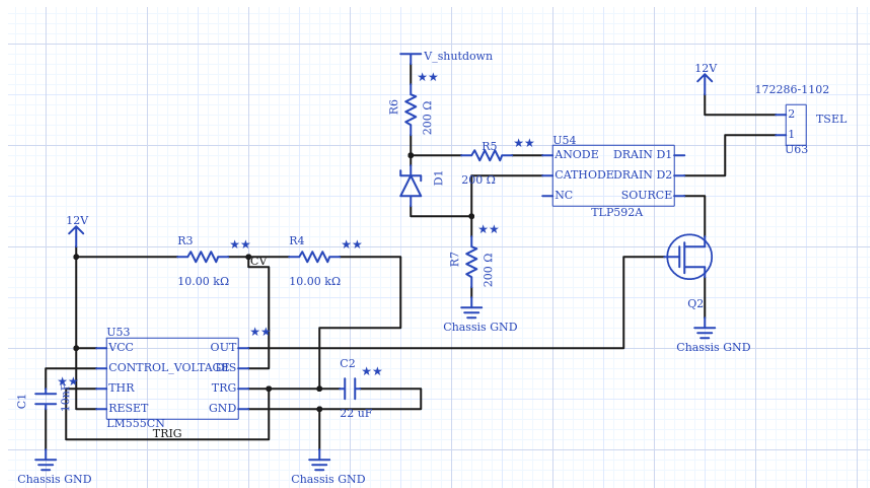

Figure 65: Schematic of the TSEL

The TSEL will be located directly under the main roll hoop. It is powered with GLV voltage taken from right before the AIR coils. When 12V is present there, it will close a photomofset and allow power to pass on the TSEL side.

## 6.6 Tractive System Voltage Present light (TSVP)

Describe the tractive system voltage present light components and method of operation. Describe location and wiring, provide schematics. See EV4.12

The TSVPs will be red lights mounted on opposite sides of the roll bar. They are powered when the TS system is over 33VDC, which is 1/3 of the maximum 100V of the TS system. The zener diode circuitry shown in figure 66 is used because the breakdown voltage of the zener will power the photo-mosfet when the TS system is over 33VDC, and not before. The lights themselves will be powered off 12V (called lights+ in the schematics) from a DC-DC converter specific to the TS system (called Lights DC-DC), which is grounded to the chassis.

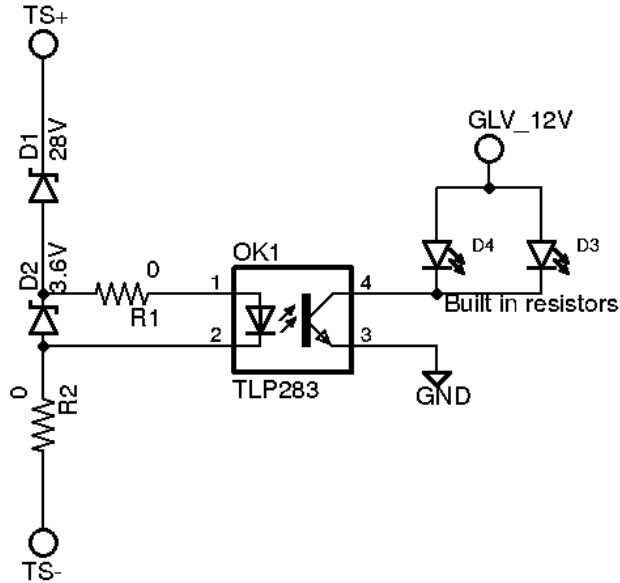

Figure 66: Schematic of the TSVPs

## 6.7 Ready-To-Drive-Sound (RTDS)

Describe your design for the RTDS system. See EV4.11

The Ready to Drive sound includes a buzzer [Mallory Sonalert SC648ANR](#) (link), a CAN node, and a relay. The buzzer automatically makes a noise when given power, with the loudness proportional to the voltage. The last step in the start-up up sequence will notify the CAN system it is time for the ready to drive sound. Then the corresponding node on the buzzer will close a relay between TS+, after a 2.6 kΩ resistor (5 Watts), and the buzzer for two seconds, at 95 dB at 2ft. The resistor limits the voltage over the buzzer to 48V (it's maximum) and the current to 20 mA.

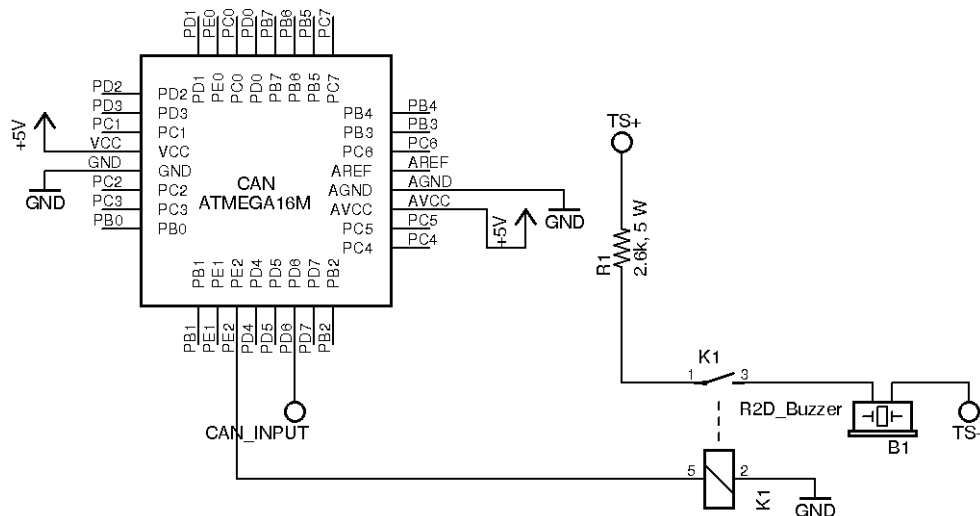

Figure 67: Schematic for the Ready to Drive Sound

## 7 GLV system

Person primarily responsible for this section:

Name: Byron Wasti  
 e-mail: Byron.wasti@students.olin.edu

### 7.1 GLV System Data

Provide a brief description of the GLV system and complete the following table

The GLV system consists of nine separate CAN nodes and all peripheral sensors. There will be a 12V line, 5V line, CAN High and CAN Low going along the car in order to power different components and to allow communications. Figure 68 shows how fusing of the GLV line is handled in reference to the main switch, e-stops, dc-dc converter and battery.

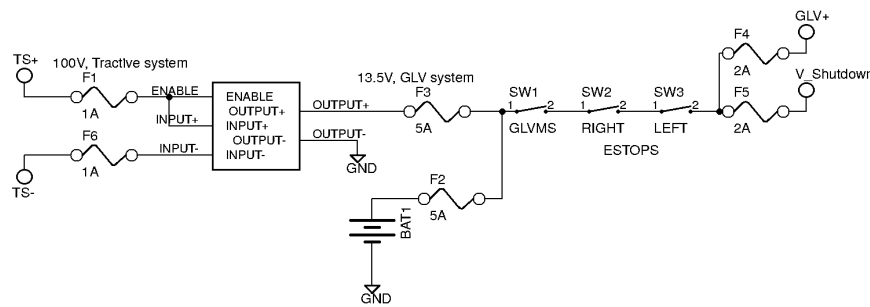

Figure 68: Schematic showing the branching, fusing and control of the GLV line

GLV System Voltage	13.5V
GLV Main Fuse Rating	5A
Is a Li-Ion GLV battery used?	No
If Yes, is a firewall provided per T4.5.1?	N/A
Is a DC-DC converter used from TSV?	Yes
Is the GLV system grounded to the chassis?	Yes
Does the design comply with EV1.2.7?	Yes

Table 34: GLV System Data

## 8 Appendices

Include only highly-relevant data. A link to a web document in the ESF text is often more convenient for the reviewer.

The specification section of the accumulator data sheet, and sections used for determining accumulator capacity (FH Rules Appendix A) should be included here.

### 1. PRODUCT AND COMPANY IDENTIFICATION

Product name : Lithium manganese oxide

Product Number : 725129  
Brand : Aldrich

Company : Sigma-Aldrich  
3050 Spruce Street  
SAINT LOUIS MO 63103  
USA

Telephone : +18003255832  
Fax : +18003255052  
Emergency Phone # : (314) 776-6555

### 2. HAZARDS IDENTIFICATION

#### Emergency Overview

**OSHA Hazards**  
Target Organ Effect

**Target Organs**  
Nerves., Lungs

#### HMIS Classification

**Health hazard:** 0  
**Chronic Health Hazard:** \*  
**Flammability:** 0  
**Physical hazards:** 0

#### NFPA Rating

**Health hazard:** 0  
**Fire:** 0  
**Reactivity Hazard:** 0

#### Potential Health Effects

**Inhalation** May be harmful if inhaled. May cause respiratory tract irritation.  
**Skin** May be harmful if absorbed through skin. May cause skin irritation.  
**Eyes** May cause eye irritation.  
**Ingestion** May be harmful if swallowed.

### 3. COMPOSITION/INFORMATION ON INGREDIENTS

Formula : LiMn2O4  
Molecular Weight : 180.81 g/mol

CAS-No.	EC-No.	Index-No.	Concentration
<b>Lithium manganese(III,IV) oxide</b>			
12057-17-9	-	-	-

### 4. FIRST AID MEASURES

#### If inhaled

If breathed in, move person into fresh air. If not breathing give artificial respiration

**In case of skin contact**

Wash off with soap and plenty of water.

**In case of eye contact**

Flush eyes with water as a precaution.

**If swallowed**

Never give anything by mouth to an unconscious person. Rinse mouth with water.

---

**5. FIRE-FIGHTING MEASURES****Suitable extinguishing media**

Use water spray, alcohol-resistant foam, dry chemical or carbon dioxide.

**Special protective equipment for fire-fighters**

Wear self contained breathing apparatus for fire fighting if necessary.

---

**6. ACCIDENTAL RELEASE MEASURES****Personal precautions**

Avoid dust formation.

**Environmental precautions**

Do not let product enter drains.

**Methods and materials for containment and cleaning up**

Sweep up and shovel. Keep in suitable, closed containers for disposal.

---

**7. HANDLING AND STORAGE****Precautions for safe handling**

Provide appropriate exhaust ventilation at places where dust is formed. Normal measures for preventive fire protection.

**Conditions for safe storage**

Keep container tightly closed in a dry and well-ventilated place.

Keep in a dry place. Keep in a dry place.

---

**8. EXPOSURE CONTROLS/PERSONAL PROTECTION**

Contains no substances with occupational exposure limit values.

**Personal protective equipment****Respiratory protection**

Respiratory protection is not required. Where protection from nuisance levels of dusts are desired, use type N95 (US) or type P1 (EN 143) dust masks. Use respirators and components tested and approved under appropriate government standards such as NIOSH (US) or CEN (EU).

**Hand protection**

For prolonged or repeated contact use protective gloves.

**Eye protection**

Safety glasses

**Hygiene measures**

General industrial hygiene practice.

---

**9. PHYSICAL AND CHEMICAL PROPERTIES****Appearance**

Form powder

Colour black

**Safety data**

pH no data available



Melting point	400 °C (752 °F)
Boiling point	no data available
Flash point	no data available
Ignition temperature	no data available
Lower explosion limit	no data available
Upper explosion limit	no data available
Water solubility	no data available

---

## 10. STABILITY AND REACTIVITY

### Chemical stability

Stable under recommended storage conditions.

### Conditions to avoid

no data available

### Materials to avoid

Strong oxidizing agents

### Hazardous decomposition products

Hazardous decomposition products formed under fire conditions. - Lithium oxides, Manganese/manganese oxides

---

## 11. TOXICOLOGICAL INFORMATION

### Acute toxicity

no data available

### Skin corrosion/irritation

no data available

### Serious eye damage/eye irritation

no data available

### Respiratory or skin sensitization

no data available

### Germ cell mutagenicity

no data available

### Carcinogenicity

IARC: No component of this product present at levels greater than or equal to 0.1% is identified as probable, possible or confirmed human carcinogen by IARC.

ACGIH: No component of this product present at levels greater than or equal to 0.1% is identified as a carcinogen or potential carcinogen by ACGIH.

NTP: No component of this product present at levels greater than or equal to 0.1% is identified as a known or anticipated carcinogen by NTP.

OSHA: No component of this product present at levels greater than or equal to 0.1% is identified as a carcinogen or potential carcinogen by OSHA.

### Reproductive toxicity

no data available

### Specific target organ toxicity - single exposure (Globally Harmonized System)

no data available

### Specific target organ toxicity - repeated exposure (Globally Harmonized System)

no data available

### Aspiration hazard

no data available

### Potential health effects

<b>Inhalation</b>	May be harmful if inhaled. May cause respiratory tract irritation.
<b>Ingestion</b>	May be harmful if swallowed.
<b>Skin</b>	May be harmful if absorbed through skin. May cause skin irritation.
<b>Eyes</b>	May cause eye irritation.

**Signs and Symptoms of Exposure**

To the best of our knowledge, the chemical, physical, and toxicological properties have not been thoroughly investigated., Men exposed to manganese dusts showed a decrease in fertility. Chronic manganese poisoning primarily involves the central nervous system. Early symptoms include languor, sleepiness and weakness in the legs. A stolid mask-like appearance of the face, emotional disturbances such as uncontrollable laughter and a spastic gait with tendency to fall in walking are findings in more advanced cases. High incidence of pneumonia has been found in workers exposed to the dust or fume of some manganese compounds., Large doses of lithium ion have caused dizziness and prostration, and can cause kidney damage if sodium intake is limited. Dehydration, weight loss, dermatological effects, and thyroid disturbances have been reported. Central nervous system effects that include slurred speech, blurred vision, sensory loss, ataxia, and convulsions may occur. Diarrhea, vomiting, and neuromuscular effects such as tremor, clonus, and hyperactive reflexes may occur as a result of repeated exposure to lithium ion.

**Additional Information**

**12. ECOLOGICAL INFORMATION**

**Toxicity**

no data available

**Persistence and degradability**

no data available

**Bioaccumulative potential**

no data available

**Mobility in soil**

no data available

**PBT and vPvB assessment**

no data available

**Other adverse effects**

no data available

**13. DISPOSAL CONSIDERATIONS**

**Product**

Observe all federal, state, and local environmental regulations.

**Contaminated packaging**

Dispose of as unused product.

**14. TRANSPORT INFORMATION**

**DOT (US)**

Not dangerous goods

**IMDG**

Not dangerous goods

**IATA**

Not dangerous goods

**15. REGULATORY INFORMATION**

**OSHA Hazards**

Target Organ Effect

**DSL Status**

This product contains the following components that are not on the Canadian DSL nor NDSL lists.

Lithium manganese(III,IV) oxide

CAS-No.  
12057-17-9

**SARA 302 Components**

SARA 302: No chemicals in this material are subject to the reporting requirements of SARA Title III, Section 302.

**SARA 313 Components**

SARA 313: This material does not contain any chemical components with known CAS numbers that exceed the threshold (De Minimis) reporting levels established by SARA Title III, Section 313.

**SARA 311/312 Hazards**

Chronic Health Hazard

**Massachusetts Right To Know Components**

No components are subject to the Massachusetts Right to Know Act.

**Pennsylvania Right To Know Components**

Lithium manganese(III,IV) oxide

CAS-No.  
12057-17-9

Revision Date

**New Jersey Right To Know Components**

Lithium manganese(III,IV) oxide

CAS-No.  
12057-17-9

Revision Date

**California Prop. 65 Components**

This product does not contain any chemicals known to State of California to cause cancer, birth defects, or any other reproductive harm.

---

**16. OTHER INFORMATION**

**Further information**

Copyright 2010 Sigma-Aldrich Co. License granted to make unlimited paper copies for internal use only. The above information is believed to be correct but does not purport to be all inclusive and shall be used only as a guide. The information in this document is based on the present state of our knowledge and is applicable to the product with regard to appropriate safety precautions. It does not represent any guarantee of the properties of the product. Sigma-Aldrich Co., shall not be held liable for any damage resulting from handling or from contact with the above product. See reverse side of invoice or packing slip for additional terms and conditions of sale.

---

### 1. PRODUCT AND COMPANY IDENTIFICATION

Product name : Lithium manganese oxide

Product Number : 725129  
Brand : Aldrich

Company : Sigma-Aldrich  
3050 Spruce Street  
SAINT LOUIS MO 63103  
USA

Telephone : +18003255832  
Fax : +18003255052  
Emergency Phone # : (314) 776-6555

### 2. HAZARDS IDENTIFICATION

#### Emergency Overview

**OSHA Hazards**  
Target Organ Effect

**Target Organs**  
Nerves., Lungs

#### HMIS Classification

**Health hazard:** 0  
**Chronic Health Hazard:** \*  
**Flammability:** 0  
**Physical hazards:** 0

#### NFPA Rating

**Health hazard:** 0  
**Fire:** 0  
**Reactivity Hazard:** 0

#### Potential Health Effects

**Inhalation** May be harmful if inhaled. May cause respiratory tract irritation.  
**Skin** May be harmful if absorbed through skin. May cause skin irritation.  
**Eyes** May cause eye irritation.  
**Ingestion** May be harmful if swallowed.

### 3. COMPOSITION/INFORMATION ON INGREDIENTS

Formula : LiMn2O4  
Molecular Weight : 180.81 g/mol

CAS-No.	EC-No.	Index-No.	Concentration
<b>Lithium manganese(III,IV) oxide</b>			
12057-17-9	-	-	-

### 4. FIRST AID MEASURES

#### If inhaled

If breathed in, move person into fresh air. If not breathing give artificial respiration

**In case of skin contact**

Wash off with soap and plenty of water.

**In case of eye contact**

Flush eyes with water as a precaution.

**If swallowed**

Never give anything by mouth to an unconscious person. Rinse mouth with water.

---

**5. FIRE-FIGHTING MEASURES****Suitable extinguishing media**

Use water spray, alcohol-resistant foam, dry chemical or carbon dioxide.

**Special protective equipment for fire-fighters**

Wear self contained breathing apparatus for fire fighting if necessary.

---

**6. ACCIDENTAL RELEASE MEASURES****Personal precautions**

Avoid dust formation.

**Environmental precautions**

Do not let product enter drains.

**Methods and materials for containment and cleaning up**

Sweep up and shovel. Keep in suitable, closed containers for disposal.

---

**7. HANDLING AND STORAGE****Precautions for safe handling**

Provide appropriate exhaust ventilation at places where dust is formed. Normal measures for preventive fire protection.

**Conditions for safe storage**

Keep container tightly closed in a dry and well-ventilated place.

Keep in a dry place. Keep in a dry place.

---

**8. EXPOSURE CONTROLS/PERSONAL PROTECTION**

Contains no substances with occupational exposure limit values.

**Personal protective equipment****Respiratory protection**

Respiratory protection is not required. Where protection from nuisance levels of dusts are desired, use type N95 (US) or type P1 (EN 143) dust masks. Use respirators and components tested and approved under appropriate government standards such as NIOSH (US) or CEN (EU).

**Hand protection**

For prolonged or repeated contact use protective gloves.

**Eye protection**

Safety glasses

**Hygiene measures**

General industrial hygiene practice.

---

**9. PHYSICAL AND CHEMICAL PROPERTIES****Appearance**

Form powder

Colour black

**Safety data**

pH no data available

Melting point	400 °C (752 °F)
Boiling point	no data available
Flash point	no data available
Ignition temperature	no data available
Lower explosion limit	no data available
Upper explosion limit	no data available
Water solubility	no data available

---

## 10. STABILITY AND REACTIVITY

### Chemical stability

Stable under recommended storage conditions.

### Conditions to avoid

no data available

### Materials to avoid

Strong oxidizing agents

### Hazardous decomposition products

Hazardous decomposition products formed under fire conditions. - Lithium oxides, Manganese/manganese oxides

---

## 11. TOXICOLOGICAL INFORMATION

### Acute toxicity

no data available

### Skin corrosion/irritation

no data available

### Serious eye damage/eye irritation

no data available

### Respiratory or skin sensitization

no data available

### Germ cell mutagenicity

no data available

### Carcinogenicity

IARC: No component of this product present at levels greater than or equal to 0.1% is identified as probable, possible or confirmed human carcinogen by IARC.

ACGIH: No component of this product present at levels greater than or equal to 0.1% is identified as a carcinogen or potential carcinogen by ACGIH.

NTP: No component of this product present at levels greater than or equal to 0.1% is identified as a known or anticipated carcinogen by NTP.

OSHA: No component of this product present at levels greater than or equal to 0.1% is identified as a carcinogen or potential carcinogen by OSHA.

### Reproductive toxicity

no data available

### Specific target organ toxicity - single exposure (Globally Harmonized System)

no data available

### Specific target organ toxicity - repeated exposure (Globally Harmonized System)

no data available

### Aspiration hazard

no data available

### Potential health effects

<b>Inhalation</b>	May be harmful if inhaled. May cause respiratory tract irritation.
<b>Ingestion</b>	May be harmful if swallowed.
<b>Skin</b>	May be harmful if absorbed through skin. May cause skin irritation.
<b>Eyes</b>	May cause eye irritation.

**Signs and Symptoms of Exposure**

To the best of our knowledge, the chemical, physical, and toxicological properties have not been thoroughly investigated., Men exposed to manganese dusts showed a decrease in fertility. Chronic manganese poisoning primarily involves the central nervous system. Early symptoms include languor, sleepiness and weakness in the legs. A stolid mask-like appearance of the face, emotional disturbances such as uncontrollable laughter and a spastic gait with tendency to fall in walking are findings in more advanced cases. High incidence of pneumonia has been found in workers exposed to the dust or fume of some manganese compounds., Large doses of lithium ion have caused dizziness and prostration, and can cause kidney damage if sodium intake is limited. Dehydration, weight loss, dermatological effects, and thyroid disturbances have been reported. Central nervous system effects that include slurred speech, blurred vision, sensory loss, ataxia, and convulsions may occur. Diarrhea, vomiting, and neuromuscular effects such as tremor, clonus, and hyperactive reflexes may occur as a result of repeated exposure to lithium ion.

**Additional Information**

**12. ECOLOGICAL INFORMATION**

**Toxicity**

no data available

**Persistence and degradability**

no data available

**Bioaccumulative potential**

no data available

**Mobility in soil**

no data available

**PBT and vPvB assessment**

no data available

**Other adverse effects**

no data available

**13. DISPOSAL CONSIDERATIONS**

**Product**

Observe all federal, state, and local environmental regulations.

**Contaminated packaging**

Dispose of as unused product.

**14. TRANSPORT INFORMATION**

**DOT (US)**

Not dangerous goods

**IMDG**

Not dangerous goods

**IATA**

Not dangerous goods

**15. REGULATORY INFORMATION**

**OSHA Hazards**

Target Organ Effect

**DSL Status**

This product contains the following components that are not on the Canadian DSL nor NDSL lists.

Lithium manganese(III,IV) oxide

CAS-No.  
12057-17-9

**SARA 302 Components**

SARA 302: No chemicals in this material are subject to the reporting requirements of SARA Title III, Section 302.

**SARA 313 Components**

SARA 313: This material does not contain any chemical components with known CAS numbers that exceed the threshold (De Minimis) reporting levels established by SARA Title III, Section 313.

**SARA 311/312 Hazards**

Chronic Health Hazard

**Massachusetts Right To Know Components**

No components are subject to the Massachusetts Right to Know Act.

**Pennsylvania Right To Know Components**

Lithium manganese(III,IV) oxide

CAS-No.  
12057-17-9

Revision Date

**New Jersey Right To Know Components**

Lithium manganese(III,IV) oxide

CAS-No.  
12057-17-9

Revision Date

**California Prop. 65 Components**

This product does not contain any chemicals known to State of California to cause cancer, birth defects, or any other reproductive harm.

---

**16. OTHER INFORMATION**

**Further information**

Copyright 2010 Sigma-Aldrich Co. License granted to make unlimited paper copies for internal use only.  
The above information is believed to be correct but does not purport to be all inclusive and shall be used only as a guide. The information in this document is based on the present state of our knowledge and is applicable to the product with regard to appropriate safety precautions. It does not represent any guarantee of the properties of the product. Sigma-Aldrich Co., shall not be held liable for any damage resulting from handling or from contact with the above product. See reverse side of invoice or packing slip for additional terms and conditions of sale.

---



## 2011 Nissan Leaf – VIN 0356

### Advanced Vehicle Testing – Beginning-of-Test Battery Testing Results



#### VEHICLE DETAILS, BATTERY DESCRIPTION AND SPECIFICATIONS

##### Vehicle Details

Base Vehicle: 2011 Nissan Leaf  
VIN: JN1AZ0CP5BT000356  
Propulsion System: BEV  
Electric Machine: 80 kW (peak), Permanent Magnet AC Synchronous, Air Cooled

##### Battery Description

Manufacturer: Automotive Energy Supply Corporation  
Type: Lithium-ion – Laminate type  
Cathode/Anode Material: LiMn<sub>2</sub>O<sub>4</sub> with LiNiO<sub>2</sub>/Graphite  
Pack Location: Under Center of Vehicle

##### Battery Specifications

Number of Cells: 192  
Cell Config.: 2 Parallel Strings of 96 in Series  
Nominal Cell Voltage: 3.8 V  
Nominal System Voltage: 364.8 V  
Rated Pack Capacity: 66.2 Ah  
Rated Pack Energy: 24 kWh  
Maximum Cell Charge Voltage<sup>2</sup>: 4.2 V  
Minimum Cell Discharge Voltage<sup>2</sup>: 2.5 V  
Thermal Mgmt.: Passive, Vacuum-Sealed Unit  
Pack Weight: 294 kg

#### BATTERY LABORATORY TEST RESULTS SUMMARY

##### Vehicle Mileage and Testing Date

Vehicle Odometer: 6,696 mi  
Date of Test: May 5, 2012

##### Static Capacity Test

Measured Average Capacity: 57.6 Ah  
Measured Average Energy Capacity: 21.0 kWh

##### EVPC Test

Pulse Discharge Power @ 80% DOD<sup>3</sup>: 201.0 kW  
Pulse Charge Power @ 20% DOD<sup>3</sup>: 71.2 kW

##### Constant-Power Discharge Test

Capacity Discharged: 56.8 Ah  
Energy Discharged: 20.0 kWh

##### NOTES:

1. Vehicle details, battery description and specifications were either supplied by the manufacturer or derived from a literature review.
2. Maximum cell charge voltage and minimum cell discharge voltage are based on similar battery chemistries from the same battery manufacturer.
3. Calculated power values based on battery charge and discharge voltage limits (see Note 3) at 80% and 20% DOD for discharge and charge power, respectively.

## Test Results Analysis

Test results for the beginning-of-testing (BOT) battery testing are provided herein. Battery test results include those from the Static Capacity Test and the Electric Vehicle Power Characterization (EVPC) Test, based on recommended test procedures from the United States Advanced Battery Consortium (USABC) at the time of testing.

### Static Capacity Test Results

Static capacity test results are summarized in the fact sheet on the previous page. The test was performed on May 5, 2012 with a vehicle odometer reading of 6,696 miles. The average measured C/3-rate capacity was 57.6 Ah compared with the manufacturer's rated capacity of 66.2 Ah. The average measured energy capacity was 21.0 kWh.

Figure 1 is a graph of battery voltage versus energy discharged. This graph illustrates the voltage values during the constant-current discharge versus the cumulative energy discharged from the battery at a C/3 discharge rate.

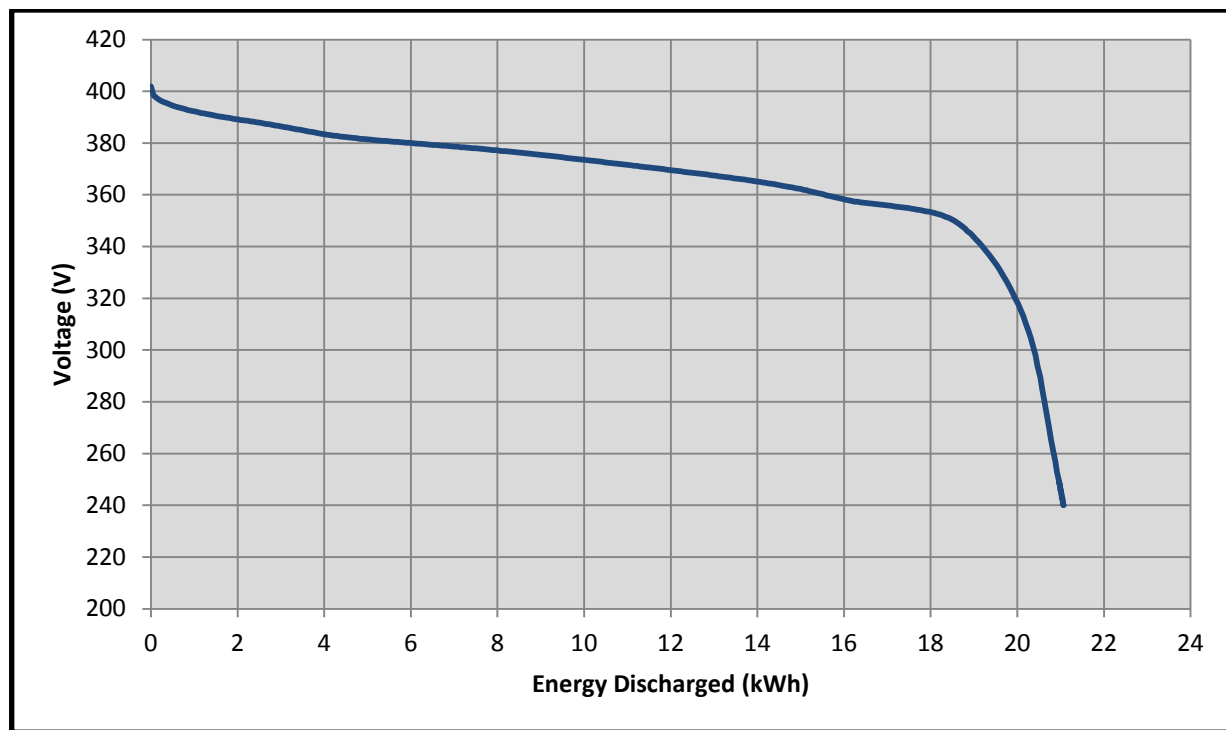

Figure 1: Voltage vs. Energy Discharged

### EVPC Test Results

EVPC test results are summarized in the fact sheet on the first page. The peak pulse discharge power is 201.0 kW at 80% depth of discharge (DOD). The peak pulse charge power is 71.2 kW at 20% DOD. The maximum and minimum cell voltages used for this analysis were 4.20 V and 2.50 V, respectively.

Figures 2 and 3 illustrate the battery's charge and discharge pulse resistance graphs which show internal resistance at various DOD. Each curve represents the resistance at the end of the specified pulse interval.

Figures 4 and 5 illustrate the battery's charge and discharge pulse power graphs which show the useable power at various DOD. Each curve represents the pulse power at the end of the specified pulse interval at the cell voltage limits.

These tests were performed for DOE's Advanced Vehicle Testing Activity (AVTA). The AVTA, part of DOE's Vehicle Technology Program, is conducted by the Idaho National Laboratory and Electric Transportation Engineering Corporation dba ECOTality North America.

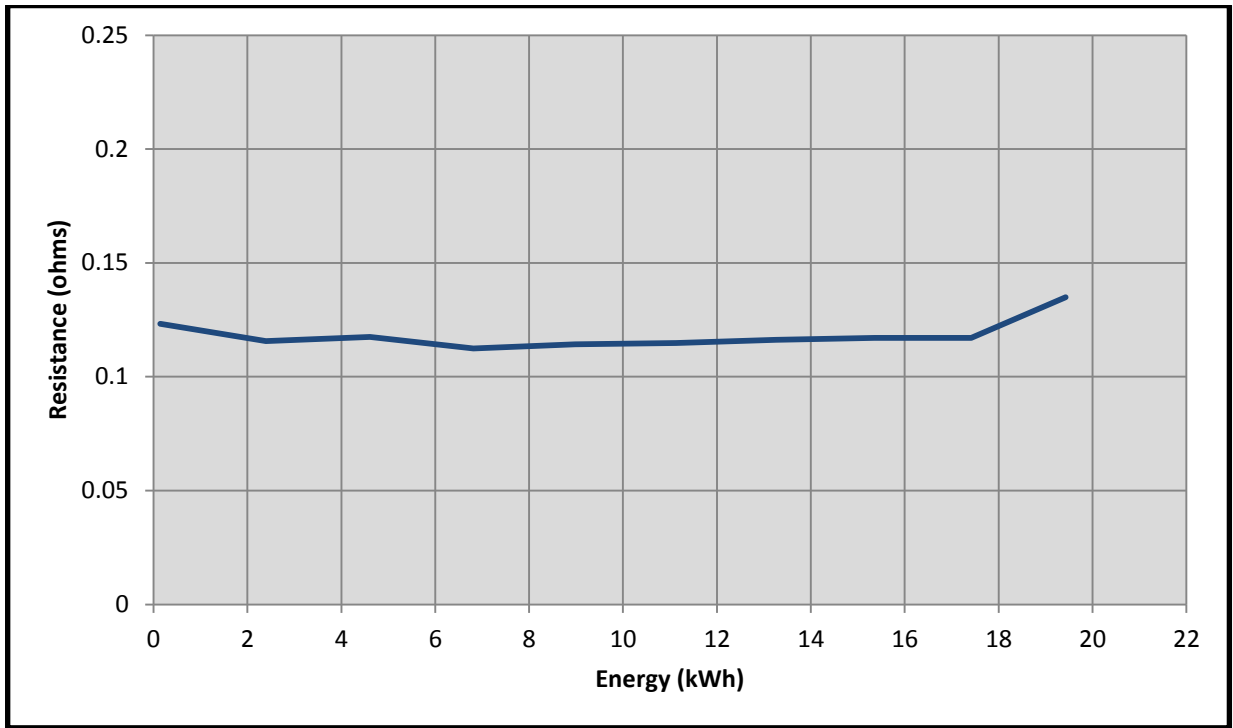

Figure 2: Charge Pulse Resistance vs. Energy Discharged

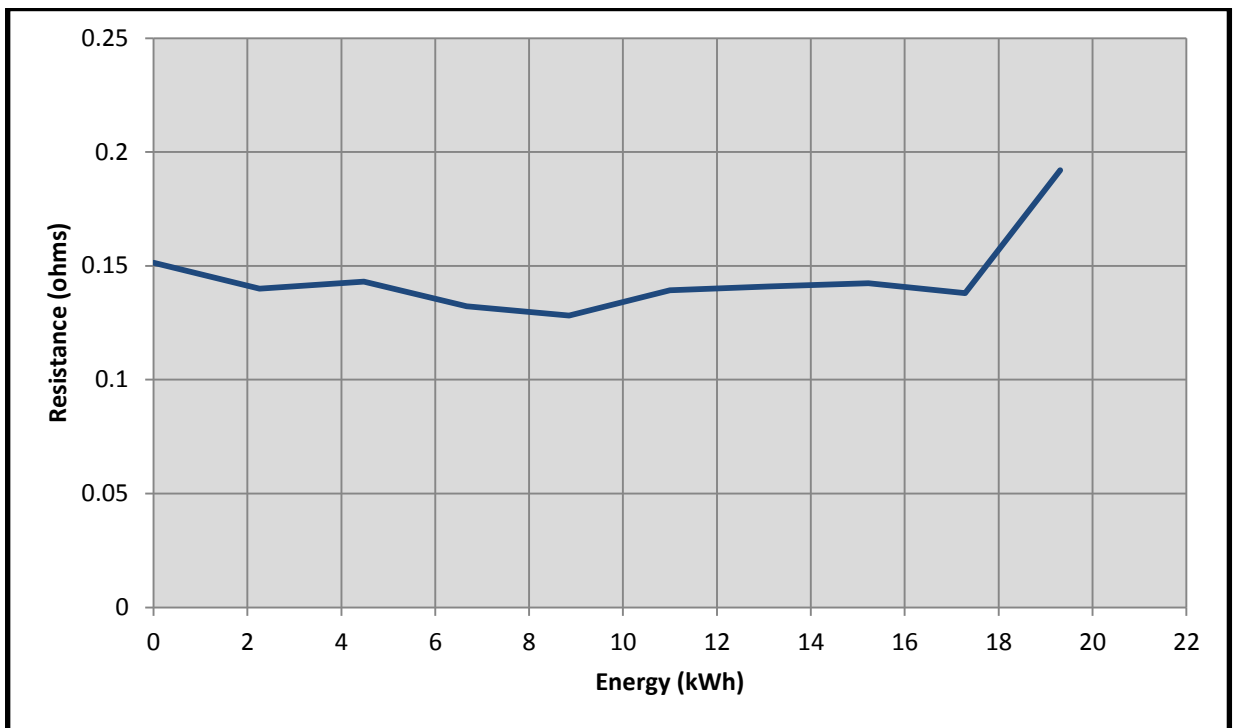

Figure 3: Discharge Pulse Resistance vs. Energy Discharged

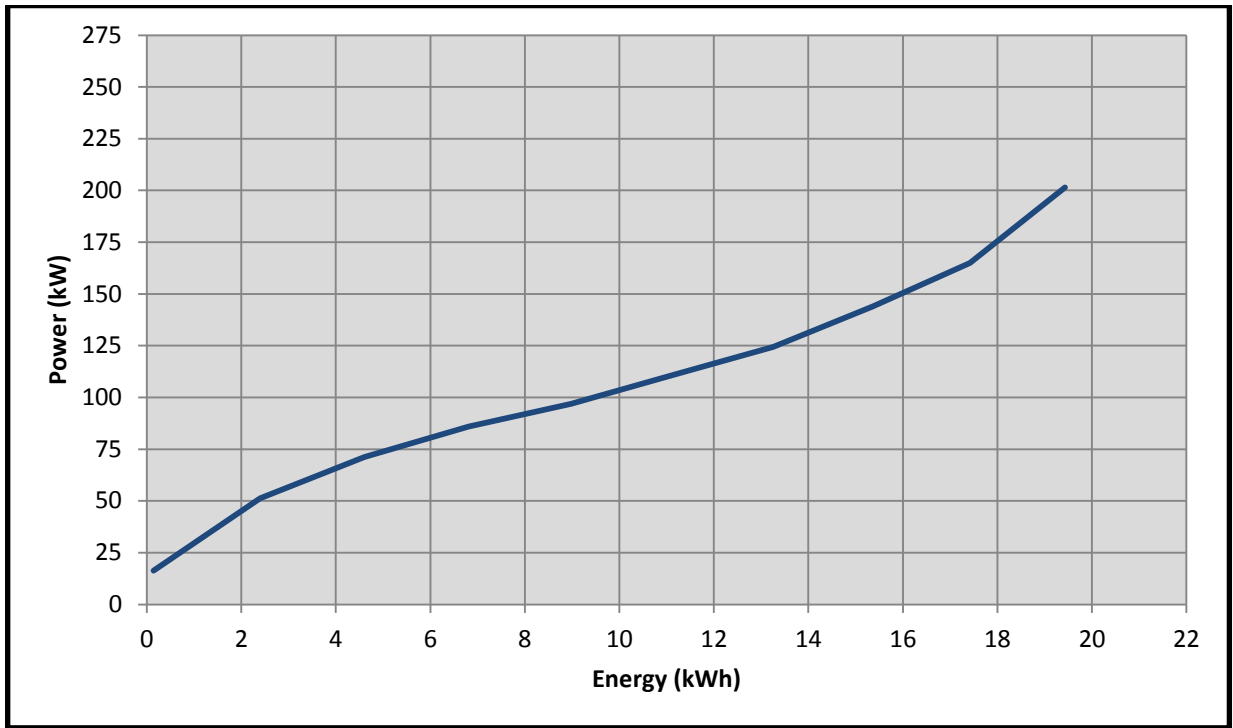

Figure 4: Charge Pulse Power vs. Energy Discharged

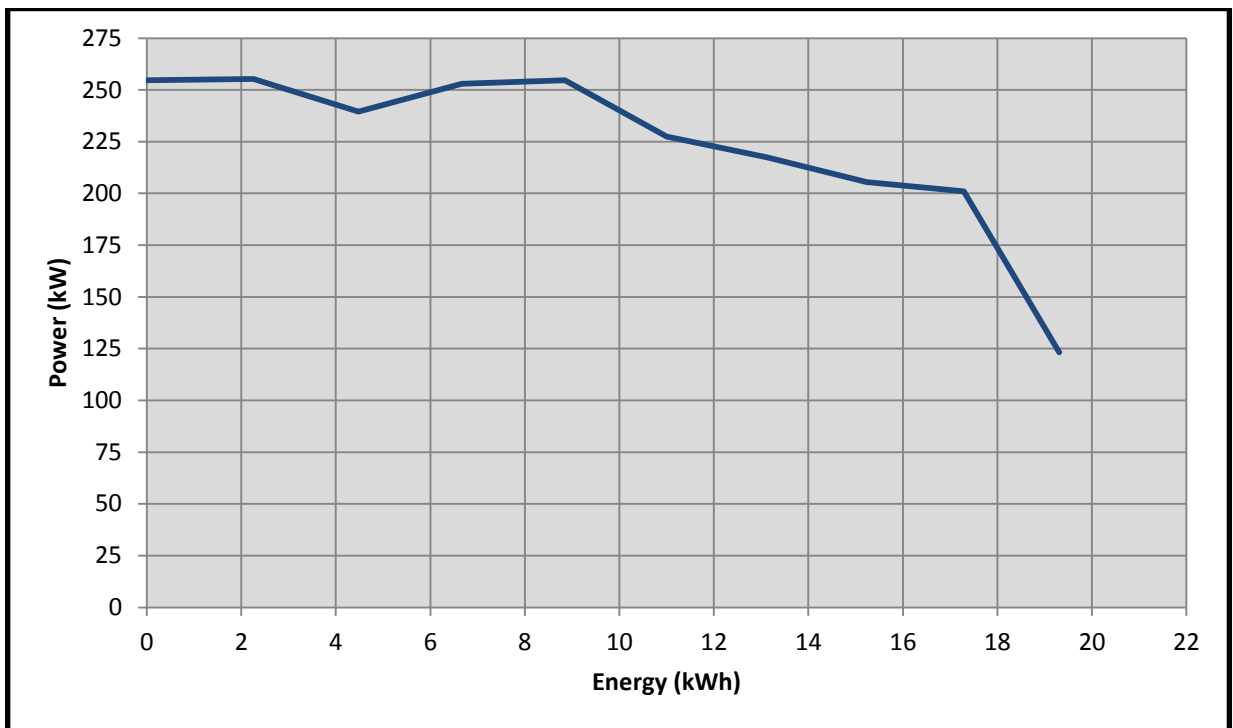

Figure 5: Discharge Pulse Power vs. Energy Discharged

**Each accumulator device will be assigned a fuel equivalency based on the following:**

**Note:** C,  $V_{nom}$ ,  $V_{peak}$  and Ah are device nameplate values at the 2C (0.5 hour) rate. To convert from manufacturer's data at other hour-rates, Peukert's equation should be used (see below).

<b>Batteries:</b>	$Energy(Wh) = (V_{nom})(Ah)(0.8)$
<b>Capacitors:</b>	$Energy(Wh) = \left( \frac{C(V_{peak}^2 - V_{min}^2)}{2} \right) / 3600$ <p>where <math>V_{min}</math> is assumed to be 10% of <math>V_{peak}</math></p>

**Table 22 – Accumulator Device Energy Calculations**

Figure 69: Selection of Appendix A used to determine accumulator capacity

[Charger \(QuiQ 1000 Series, Delta Q Technologies, specifications\)](#)